

HEALTH SCIENCES PATHWAY



Welcome to Gulf Coast and to the Health Sciences Pathway!

Guided Pathways

Guided Pathways is a GCSC endeavor to provide students with an academic plan that guides students along a path to reach their academic and career goals. By grouping fields of study by similarities, students can explore options that reflect their interests, experience the best preparation for success, and efficiently pursue university transfer of their chosen field.

The six Pathways are identified as the following:

Business, Industry, Technology, and Manufacturing

Health Sciences

Humanities, Arts, Design, and Communication

Public Safety

Science, Technology, Engineering, and Mathematics

Social, Behavioral Sciences, and Education

Pathway Navigators provide initial academic advising and assist students in finding their way around GCSC. The Pathway Navigator is assigned to the broader Pathway and is knowledgeable about the general “area.”

Faculty Advisors work with students to provide more in-depth guidance about the students’ chosen program of study. Faculty Advisors are knowledgeable about the specific major or program of study, and work with students to enhance their university transfer or professional opportunities upon program completion.

Programs, majors, and degrees are organized within the Guided Pathways to help students explore their options. Milestone Courses, coursework within an academic program that provides critical skills development for student success in the academic program, are noted in each program with an asterisk(*).

The Health Sciences Pathway is designed for students who are interested in pursuing advanced study that focuses on skills necessary for careers in the allied health professions. Students will gain and develop skills such as problem-solving, patient-care skills, organizational skills, and specific technical skills that will position them to excel in their chosen health care field.

Disclaimer: Gulf Coast State College makes every reasonable effort to provide accurate information in the contents of this catalog but reserves the right to make changes at any time without prior notice.

Curriculum in this catalog is up to date as of April 1, 2023.

Health Sciences Pathway

The Pathway Navigators for Health Sciences are:

Mimi McGee – office is on the second floor of the Student Union East

Alyssa Evans – office is on the second floor of the Health Sciences Building

The following programs of study are included in the Health Sciences Pathway and the Pathway Navigators assigned to each:

Dental Hygiene and Assisting – Mimi McGee

Health Sciences – Mimi McGee

Nutrition Studies – Mimi McGee

Physical Therapist Assistant – Mimi McGee

Radiography – Alyssa Evans

Respiratory Care – Alyssa Evans

Sonography – Mimi McGee

Surgical Assistant/Surgical Services – Alyssa Evans

Nursing – Mimi McGee

Each program of study is detailed alphabetically in the following pages. Programs of study also indicate the type of degree the student can earn at Gulf Coast State College.

Associate in Arts Degree (AA) – University Transfer Degree – Designed as a “transfer track” using the Florida Department of Education Common Prerequisite Manual.

All A.A. students entering a Florida College system institution in Fall 2021 and thereafter, are required to meet civic literacy requirements by passing either AMH2020 or POS2041 and passing the Florida Civic Literacy Examination (FCLE).

Students may also demonstrate competency through completion of AP Government and Politics: United States, AP United States History, or CLEP: American Government examination. AICE: U.S. History (1840 – 1990) meets the civic literacy course requirement only. Students receiving course credit for this exam will be required to pass the FCLE. High school students who take the U.S. Government course and pass the FCLE will have met the postsecondary civic literacy assessment requirement. Students who have previously achieved a passing score on an approved assessment or passed an approved course will have met the assessment requirement or coursework requirement, respectively, and will not be required to re-take the assessments or courses.

Associate in Science Degree (AS) – Workforce Degree – Designed to prepare students for immediate employment - does not transfer to the University as a whole.

All A.S. students entering a Florida College System institution in Fall 2022 and thereafter, are required to meet civic literacy requirements by passing either AMH2020 or POS2041 and passing the Florida Civic Literacy Examination (FCLE).

Students may also demonstrate competency through

completion of AP Government and Politics: United States, AP United States History, or CLEP: American Government examination. AICE: U.S. History (1840 – 1990) meets the civic literacy course requirement only. Students receiving course credit for this exam will be required to pass the FCLE. High school students who take the U.S. Government course and pass the FCLE will have met the postsecondary civic literacy assessment requirement. Students who have previously achieved a passing score on an approved assessment or passed an approved course will have met the assessment requirement or coursework requirement, respectively, and will not be required to re-take the assessments or courses.

Baccalaureate Degree (Bachelor of Applied Science or Bachelor of Science in Nursing) – Students must have an earned AA or AS Degree with specific prerequisites to apply for a Baccalaureate Degree program.

Workforce Certificate (College Career Certificate or Vocational Certificate) – A short-term credential designed for immediate employment in a specific field.

Estimated annual salary range for Health Sciences program graduates is \$30,000 - \$80,000.

Dental Assisting – Career Certificate (DEAS-VC)

AREA OF CONCENTRATION: The purpose of this limited access, selective admissions program is to provide students with the educational background and clinical competencies necessary in the field of dental assisting. The program is accredited by the Commission on Dental Accreditation (CODA) of the American Dental Association. After successful completion of the program, graduates are eligible to take the Dental Assisting National Board Examination (DANB) for certification. The program can be completed in as little as ten (10) months.

To apply for this program of study, students should obtain a program application packet from the Division of Health Sciences offices or on the college website, under Academics>Academic Divisions>Health Sciences.

Program Coordinator: Laurie Womble 850.727.3217

Professional Licensure Disclosure

Gulf Coast State College is approved to offer programs that may lead to professional licensure or certification in Florida. GCSC does not guarantee that programs which fulfill Florida licensing requirements will satisfy the criteria of professional licensure boards in other states, as each state has unique requirements for professional licensure or certification which are subject to change at any time and without notice.

Enrolled students and prospective students are strongly encouraged to contact their state's licensure entity to review all licensure or certification requirements imposed by their state(s) of choice. Please review the licensing board for guidance on the professional licensure or certification requirements for programs in your home state or where you would like to practice professionally.

GCSC is required by the National Council for State Authorization Reciprocity Agreements (NC-SARA) to disclose whether your prospective program meets the professional licensure or certification requirements in other states. NC-SARA does not address professional licensure issues. <https://gulfcoast.edu/academics/online/professional-licensure-disclosure.html>

Admissions: The Dental Assisting program is a limited access program beginning each fall semester. A selective admissions policy with specific selection criteria is utilized in order to select the most qualified applicants. The strength of the applicant pool varies year-to-year, with the best qualified applicants receiving first consideration. It is the applicant's responsibility to inquire about these specific admission and selection criteria and to ensure that all required documents are received on campus prior to the published deadline in the current application packet.

PLEASE NOTE: Gulf Coast State College is not requiring a COVID-19 vaccination. However, students completing clinical/practicum experiences in agencies and clinical sites that bill patients under Medicare and Medicaid must be fully vaccinated against COVID-19 or have received an exemption according to the CMS Interim Final Rule. Gulf Coast State College Health Sciences students will be asked to report vaccination status (vaccinated or not vaccinated) to the program for clinical placement purposes. Exemptions to clinical site vaccination requirements will occur between the clinical site and the student because GCSC does not have a COVID-19 vaccination requirement.

Provisional Admission Requirements:

- A. Apply to Gulf Coast State College. General admission to the college must be granted prior to applying to the Dental Assisting program. General admission to Gulf Coast State College **does not** imply acceptance into the Dental Assisting program
- B. Current TABE or CPT/PERT scores (successful completion required for graduation). Demonstrated 10th grade competency level in reading, language, and math satisfied by current placement test scores or successful completion ("C" or higher) in equivalent college-level courses
- C. Official high school transcript or GED and all official college transcripts sent to Enrollment Services for evaluation
- D. Completed program application including:
 1. Dental Assisting application
 2. Technical Standards form
 3. Placement Test Requirement form
 4. Additional documents as specified

Requirements after Provisional Acceptance

- A. Report of Vaccination History to include:
 1. Hepatitis B Surface Antigen test
 2. Hepatitis B vaccine series, if surface antigen is positive (or signed declination waiver)
 3. PPD Mantoux/TB Test annually (may require chest radiograph if previously positive PPD Mantoux/TB test)
 4. MMR (Measles, Mumps, Rubella)
 5. Varicella (Chickenpox)
 6. Tetanus-Diphtheria (Tetanus every 10 years)
- B. Copy of current Cardiopulmonary Resuscitation (CPR) Certificate (BLS for Healthcare Providers) by the AHA
- C. Satisfactory fingerprint/criminal background check
- D. Interprofessional Healthcare Training (every 2 years)
 1. HIPAA
 2. HIV/AIDS
 3. Prevention of Medical Errors
 4. Domestic Violence
 5. Infection Control
 6. Human Trafficking
 7. Interprofessional Education
 8. Airborne Precautions w/Mask Fit

- E. Satisfactory physical examination (signed by a licensed healthcare provider)
- F. Satisfactory drug screening results

Readmission Guidelines

1. A student who withdraws from or earns a grade lower than a "C" in a Dental Assisting course will not be permitted to continue in the Dental Assisting Program. A student who does not meet the Technical Standards of the program will not be permitted to continue in the program.
2. Applicants who wish to apply for readmission should do so prior to March 15 (if planning to enroll in the fall semester) or October 1 (if planning to enroll in the spring semester).
3. A student who applies for readmission to the Dental Assisting program must provide significant evidence that suggests the potential for future success in the program. This evidence may address such things as unusual circumstances, remedial study, and/or additional preparation.
4. Readmission to the Dental Assisting Program will be dependent upon available resources.
5. In order to be considered for readmission by the Admissions Committee, the applicant must do the following:
 - a. Submit a written request letter (not e-mail) to the Dental Assisting Coordinator presenting evidence to justify readmission. This may include letters of recommendation from a previous faculty member or coordinator, additional coursework, work experience, etc.
 - b. Meet current guidelines for admission to the College and the Dental Assisting Program.
6. Readmission may be contingent upon the candidate's agreeing to audit previously completed coursework.

Transfer Policy

Applicants who wish to transfer from another Dental Assisting Program to a GCSC Dental Program must: 1) meet all current admission requirements, 2) apply at least two months prior to the expected date of enrollment, 3) notify the Dental Assisting Coordinator in writing, stating anticipated entry date and reason for transfer, 4) provide evidence of successful completion of previous core dental courses from an American Dental Association accredited program, and 5) provide a letter from the program chair stating that the student is in good academic standing and clinical standing and is eligible to return to the Dental Assisting program they wish to transfer from. Acceptance of any transfer student will be dependent upon available resources.

Articulation Policy

Students who elect to articulate must have completed said courses with a grade of "C" or better from an American

Dental Association accredited Dental Assisting Program within the last three years *and* have actively been working in the dental field at least 3 months prior to entrance in the program. If you feel you meet articulation requirements, please contact the Dental Assisting Coordinator for more information.

Curriculum Detail

Course Number	Course Name/Course Area	Credit Hours
DEA0020C	Pre-Clinical Procedures	182 ct/6 v
DEA0132	Dental Nutrition	32 ct/1 v
DEA0133	Introduction to Microbiology	16 ct/1 v
DEA0134	Introductory Pharmacology/Dental Office Emergencies	32 ct/2 v
DEA0800L	Clinical Practice I	48 ct/1.5 v
DEA0801	Clinical Practice II	56 ct/2 v
DEA0801L	Clinical Practice II Lab	198 ct/6 v
DEA0850L	Clinical Practice III Lab	192 ct/6.5 v
DEH1400	Oral Pathology	32 ct/2
DES0501	Dental Practice Management	32 ct/1 v
DES0844	Dental Health Education	32 ct/1 v
DES1000	Dental Anatomy	32 ct/2
DES1010	Head & Neck Anatomy	32 ct/2
DES1100	Dental Materials	30 ct/2
DES1200	Dental Radiology I	32 ct/2
DES1200L	Dental Radiology I Lab	45 ct/1
DES1201	Dental Radiology II	17 ct/1
DES1201L	Dental Radiology II Lab	45 ct/1
DES1320	Basic Communications & Human Relations	17 ct/1
DES1404	Introductory Anatomy & Physiology	32 ct/2
DES1832	Expanded Functions	17 ct/1
DES1832L	Expanded Functions Lab	45 ct/1
TOTAL CREDIT HOURS		408 ct/19 v
TOTAL VOCATIONAL HOURS		822 ct/28
TOTAL CERTIFICATE HOURS		1230 ct/46 v

Dental Hygiene (DENH-AS)

AREA OF CONCENTRATION: The Dental Hygiene Program is a limited access, selective admissions program designed to assist students in developing and mastering basic clinical competencies and theoretical concepts of dental hygiene practice. Graduates will receive an AS degree in Dental Hygiene and will be eligible to apply for the national and state board examinations in any state. The Dental Hygiene Program is accredited by the American Dental Association Commission on Dental Accreditation. Students are encouraged to complete as many of the general education courses as possible prior to seeking admission into the program. Because of limited enrollment, students are encouraged to prepare application requirements in the fall for the next year's class. **This is a Limited Access Program.**

Program Coordinator: Miranda Stewart 850.769.1551 x3244

To apply for this program of study, students should obtain a program application packet from the Division of Health Sciences offices or on the college website, under Academics>Academic Divisions>Health Sciences.

ADMISSIONS: The Dental Hygiene Program is a limited access program beginning each fall semester. A selective admissions policy with specific selection criteria is utilized in order to select the most qualified applicants. The strength of the applicant pool varies year-to-year, with the highest qualified applicants receiving first consideration. It is the applicant's responsibility to inquire about these specific admission and selection criteria and to ensure that all required documents are received on campus prior to the deadline published in the current application packet.

PLEASE NOTE: Gulf Coast State College is not requiring a COVID-19 vaccination. However, students completing clinical/practicum experiences in agencies and clinical sites that bill patients under Medicare and Medicaid must be fully vaccinated against COVID-19 or have received an exemption according to the CMS Interim Final Rule. Gulf Coast State College Health Sciences students will be asked to report vaccination status (vaccinated or not vaccinated) to the program for clinical placement purposes. Exemptions to clinical site vaccination requirements will occur between the clinical site and the student because GCSC does not have a COVID-19 vaccination requirement.

Professional Licensure Disclosure

Gulf Coast State College is approved to offer programs that may lead to professional licensure or certification in Florida. GCSC does not guarantee that programs which fulfill Florida licensing requirements will satisfy the criteria of professional licensure boards in other states, as each state has unique requirements for professional licensure or certification which are subject to change at any time and without notice.

Enrolled students and prospective students are strongly encouraged to contact their state's licensure entity to review all licensure or certification requirements imposed by their state(s) of choice. Please review the licensing board for guidance on the professional licensure or certification requirements for programs in your home state or where you would like to practice professionally.

GCSC is required by the National Council for State Authorization Reciprocity Agreements (NC-SARA) to disclose whether your prospective program meets the professional licensure or certification requirements in other states. NC-SARA does not address professional licensure issues. <https://gulfcoast.edu/academics/online/professional-licensure-disclosure.html>

Provisional Admission Requirements:

- A. Application to Gulf Coast State College. Apply to Gulf Coast State College. General admission to the college must be granted prior to applying to the Dental Hygiene program. General admission to Gulf Coast State College **does not** imply acceptance into the Dental Hygiene program.
- B. Official high school transcript or GED **and** all official college transcripts sent to Enrollment Services for evaluation
- C. Demonstration of Math/Algebra, English and Reading competency via current (within 2 years) CPT/PERT scores or ACT/SAT equivalent. Approved college-level courses in Math/Algebra, English and Reading may also satisfy competency requirements
- D. Application to Dental Hygiene Program, including:
 1. Dental Hygiene Application
 2. Technical Standards Form
 3. Additional documentation as specified in the current application

Requirements after Provisional Acceptance

- A. Completion of prerequisite courses with a grade of "C" or better prior to first year fall - term 2
 1. BSC2085, Anatomy & Physiology I
 2. BSC2085L, Anatomy & Physiology I Lab
 3. ENC1101, English Composition I
 4. HUN1201, Principles of Nutrition
- B. Report of Vaccination History to include:
 1. Hepatitis B Surface Antigen test
 2. Hepatitis B vaccine series, if surface antigen is positive (or signed declination waiver)
 3. PPD Mantoux/TB Test (may require chest radiograph if previously positive PPD Mantoux/TB test)
 4. MMR (Measles, Mumps, Rubella)
 5. Varicella (Chickenpox)
 6. Tetanus-Diphtheria (Tetanus every 10 years)
- C. Copy of current Cardiopulmonary Resuscitation (CPR) certificate (BLS for Healthcare Providers) by the AHA
- D. Satisfactory fingerprint/criminal background check
- E. Interprofessional Healthcare Training (every 2 years)

1. HIPAA
 2. HIV/AIDS
 3. Prevention of Medical Errors
 4. Domestic Violence
 5. Infection Control
 6. Human Trafficking
 7. Interprofessional Education
 8. Airborne Precautions w/Mask Fit
- F. Satisfactory physical examination (signed by physician/HCP)
- G. Satisfactory drug screening results

Readmission Guidelines

1. A student who withdraws from or earns a grade lower than a "C" in one of the approved science courses and/or in a Dental Hygiene course will not be permitted to continue in the Dental Hygiene Program. A student who does not meet the Technical Standards of the program will not be permitted to continue in the program.
2. Applicants who wish to apply for readmission should do so prior to March 1 if planning to enroll in the fall semester or October 1 if planning to enroll in the spring semester.
3. Readmission to the Dental Hygiene Program will be dependent upon available resources.
4. In order to be considered for readmission by the Admissions Committee, the applicant must do the following:
 - a. Submit a written request letter (not e-mail) to the Dental Hygiene Coordinator presenting evidence to justify readmission. This may include letters of recommendation from a previous faculty member or coordinator, additional coursework, work experience, etc.
 - b. Meet current guidelines for admission to the College and the Dental Hygiene Program.
5. Readmission may be contingent upon the candidate's agreeing to audit previously completed coursework.
6. A student who applies for readmission to the Dental Hygiene Program must provide significant evidence that suggests the potential for future success in the program. This evidence may address such things as unusual circumstances, remedial study, and/or additional preparation.

Transfer Policy

Applicants who wish to transfer from another Dental Hygiene Program to a GCSC Dental Hygiene Program must 1) meet all current admission requirements, 2) apply at least two months prior to the expected date of enrollment, 3) notify the Dental Hygiene Coordinator in writing, stating anticipated entry date and reason for transfer, 4) provide evidence of successful completion of previous core dental courses from an American Dental Association accredited program, and 5) provide a letter from the program chair stating that the student is in good academic and clinical standing and is eligible to return

to the Dental Hygiene Program they wish to transfer from. Acceptance of any transfer student will be dependent upon available resources.

Transferability of GCSC Dental Hygiene courses to another institution will be dependent upon the acceptance of the receiving institution.

Articulation Policy

Students who elect to articulate must have completed said courses with a grade of "C" or better from Gulf Coast State College's accredited Dental Assisting Program within the last three years and have actively been working in the dental field at least three months prior to entrance in the program. If you feel you meet articulation requirements, please contact the Dental Hygiene Coordinator for more information.

Curriculum Detail

Course Number	Course Name/Course Area	Credit Hours
Communications Area – 3 credit hours		
ENC1101 OR ENC1101C	English Composition I OR Enhanced English Composition	3
Humanities Area – 3 credit hours		
	Visual & Performing Arts OR Philosophy/Religion OR Literature	3
Mathematics Area – 3 credit hours		
	College-level mathematics	3
Natural Sciences Area – 3 credit hours		
BSC2085	Anatomy & Physiology I	3
Social Sciences Area – 6 credit hours		
PSY2012	Psychology	3
POS2041 OR AMH2020	American National Government OR US History II	3
General Education Courses – 18 credit hours		
SYG2000	Sociology	3
BSC2085L	Anatomy & Physiology I Lab	1
BSC2086	Anatomy & Physiology II	3
BSC2086L	Anatomy & Physiology II Lab	1
MCB2004	Microbiology	3
MCB2004L	Microbiology Lab	1
HUN1201	Principles of Nutrition	3
SPC1608	Introduction to Public Speaking	3
Major Courses – 52 credit hours		
DES1000	Dental Anatomy	2
DES1010	Head & Neck Anatomy	2
DES1100C	Dental Materials	3
DES1200	Dental Radiology I	2

DES1200L	Dental Radiology I Lab	1
DES1201	Dental Radiology II	1
DES1201L	Dental Radiology II Lab	1
DES1832	Expanded Functions	1
DES1832L	Expanded Functions Lab	1
DEH1002	Fundamentals of Dental Hygiene	3
DEH1002L	Dental Hygiene Pre-Clinical Procedures	3
DEH1130	Oral Histology & Embryology	2
DEH1400	Oral Pathology	2
DEH1800	Dental Hygiene I	2
DEH1800L	Dental Hygiene Clinical I	4
DEH1802	Dental Hygiene II	1
DEH1802L	Dental Hygiene Clinical II	2
DEH2300	Pharmacology for the Dental Hygienist	2
DEH2602	Periodontology	2
DEH2702	Community Dental Health	2
DEH2702L	Community Dental Health Lab	1
DEH2804	Dental Hygiene III	2
DEH2804L	Dental Hygiene Clinical III	4
DEH2806	Dental Hygiene IV	2
DEH2806L	Dental Hygiene Clinical IV	4
TOTAL DEGREE HOURS		88

Nutrition, Food, & Exercise Science Option, Liberal Arts AA (NUTS-AA)

AREA OF CONCENTRATION: The purpose of this university transfer track is to prepare students for transfer into a baccalaureate degree program that will prepare students to become dietitians and nutritionists. In addition, the baccalaureate program will also prepare the student for institutional food service administration and product development for the food industry.

Faculty Advisor: Sabrina Elliott 850.769.1551 x5888

Curriculum Detail

Course Number	Course Name/Course Area	Credit Hours
Communications Area – 6 credit hours		
ENC1101 OR ENC1101C	English Composition I OR Enhanced English Composition	3
ENC1102	English Composition II	3
Humanities Area – 9 credit hours		
	Visual and Performing Arts	3
	Philosophy/Religion	3
	Literature	3
Mathematics Area – 6 credit hours		
STA2023*	Statistics	3
MAC1105	College Algebra	3
Natural Sciences Area – 6 credit hours		
CHM1045*	General Chemistry	3
BSC2010*	Biology for Science Majors	3
Social Sciences Area – 9 credit hours		
	Behavioral Science	3
	History	3
POS2041	American National Government	3
Transfer Common Prerequisites – 15 credit hours		
BSC2010L	Biology for Science Majors Lab	1
BSC2085	Anatomy & Physiology I	3
BSC2085L	Anatomy & Physiology I Lab	1
BSC2086	Anatomy & Physiology II	3
BSC2086L	Anatomy & Physiology II Lab	1
CHM1045L	General Chemistry Lab	1
CHM1046	General Chemistry with Qualitative Analysis	3
CHM1046L	General Chemistry with Qualitative Analysis Lab	1
HUN1201	Principles of Nutrition	3
MCB2004	Microbiology	3
MCB2004L	Microbiology Lab	1
Electives – 3 credit hours		3
TOTAL DEGREE HOURS		60

*Milestone Courses

Physical Therapist Assistant (PTA-AS)

AREA OF CONCENTRATION: Upon successful completion of the prescribed course of study, students will receive an Associate in Science degree. Graduates are eligible to take the Physical Therapist Assistant licensing examination and the Florida Laws and Rules examination. Graduates planning to be employed in Florida are required, under Chapter 486, Florida State Physical Therapy Practice Act, to be licensed. The Physical Therapist Assistant program is an intensive, full-time program that is designed to be completed in two years. Once selected into the program, the courses must be taken sequentially and are offered only once per year. **This is a Limited Access Program.**

The Physical Therapist Assistant program at GCSC is accredited by the Commission on Accreditation in Physical Therapy Education (CAPTE), 3030 Potomac Ave., Suite 100, Alexandria, Virginia 22305-3085; telephone: 703-706-3245; email: accreditation@apta.org; website: <http://www.capteonline.org>. If needing to contact the program/institution directly, please call 850-913-3312 or email mcumbaa@gulfcoast.edu

Program Coordinator: Melinda Cumbaa 850.913.3312

Professional Licensure Disclosure

Gulf Coast State College is approved to offer programs that may lead to professional licensure or certification in Florida. GCSC does not guarantee that programs which fulfill Florida licensing requirements will satisfy the criteria of professional licensure boards in other states, as each state has unique requirements for professional licensure or certification which are subject to change at any time and without notice.

Enrolled students and prospective students are strongly encouraged to contact their state's licensure entity to review all licensure or certification requirements imposed by their state(s) of choice. Please review the licensing board for guidance on the professional licensure or certification requirements for programs in your home state or where you would like to practice professionally.

GCSC is required by the National Council for State Authorization Reciprocity Agreements (NC-SARA) to disclose whether your prospective program meets the professional licensure or certification requirements in other states. NC-SARA does not address professional licensure issues.
<https://gulfcoast.edu/academics/online/professional-licensure-disclosure.html>

PLEASE NOTE: Gulf Coast State College is not requiring a COVID-19 vaccination. However, students completing clinical/practicum experiences in agencies and clinical sites that bill patients under Medicare and Medicaid must be fully vaccinated against COVID-19 or have received an exemption according to the CMS Interim Final Rule. Gulf Coast State

College Health Sciences students will be asked to report vaccination status (vaccinated or not vaccinated) to the program for clinical placement purposes. Exemptions to clinical site vaccination requirements will occur between the clinical site and the student because GCSC does not have a COVID-19 vaccination requirement.

Application Process:

- A. Apply to Gulf Coast State College. General admission to the college must be granted prior to applying to the Physical Therapist Assistant program. General admission to Gulf Coast State College **does not** imply acceptance into the Physical Therapist Assistant program.
- B. Official high school transcript or GED and official college transcripts from each college or university attended must be received and evaluated by the GCSC Office of Enrollment Services. A minimum overall GPA of 2.5 is required. Preference is given to those students with a science background.
- C. Demonstration of math/algebra, English, and reading competency via current (within 2 years) CPT/PERT scores or ACT/SAT equivalent. Approved college-level courses in math/algebra, English, and reading may also satisfy competency requirements as listed in the application packet.
- D. Apply to the Physical Therapist Assistant program by the spring deadline as published in the Physical Therapist Assistant program application packet. One class per year will be admitted the following fall semester. Students not admitted for the year in which they applied must reapply if they wish to be considered for entry in a subsequent year. There is no waiting list. The Physical Therapist Assistant program application includes:
 1. Physical Therapist Assistant Program Application
 2. Technical Standards Form
 3. Additional documentation if applicable (as specified in the Application Packet, e.g., work/observation form)

Requirements after Conditional Acceptance:

- A. Transcripts: If completing a college-level course after the application deadline please submit an updated transcript to Enrollment Services. If high school graduation occurs after the application deadline, official high school transcripts must be received by Enrollment Services prior to the first semester (fall term).
- B. Submit satisfactory physical examination (signed by licensed medical professional)
- C. Submit and maintain a report of vaccination history
- D. Complete satisfactory level II background check and drug screening results (required annually, and at the request of individual clinical sites per facility requirements)
- E. Attend Physical Therapist Assistant Program Orientation
- F. Complete Interprofessional Healthcare Training in August prior to the first semester (fall term). This includes:

- Hospital Orientation
 - HIPAA Training
 - HIV/AIDS Training
 - Prevention of Medical Errors
 - Domestic Violence Training
 - Infection Control Training
 - Interprofessional Education
 - Airborne Precautions w/Mask Fit
 - Human Trafficking
- G. Submit a copy of current Cardiopulmonary Resuscitation (CPR) certificate (BLS for Healthcare Providers) by the AHA. This should be completed by the end of the first semester (fall term). Students must also demonstrate competency in Civic Literacy pursuant to s.1007.25 F.S.
- H. Completion of all curriculum courses with a grade of “C” or better. All general education courses (courses that do not start with PHT) should be completed by the end of the third semester (summer term), prior to beginning clinical coursework.
- I. Provide proof of health insurance upon request for clinical placement, during third semester. (If a student does not have health insurance this may limit clinical site availability/selections.)
- J. Comply with program policies. Specific program policies can be found in the Physical Therapist Assistant Program Handbook.

Readmission Guidelines:

A student who withdraws from or earns a grade lower than a “C” in one of the approved science courses and/or in a technical (PHT) course will not be permitted to progress in the Physical Therapist Assistant Program. A student who does not meet the Technical Standards of the program will not be permitted to continue in the program.

- A. Applicants who wish to apply for readmission should do so by the May application deadline, prior to the upcoming fall semester they wish to enter. Students who fail to obtain a minimum of a “C” in two or more PHT courses will be ineligible for readmission.
- B. Readmission to the Physical Therapist Assistant program is not guaranteed and will be dependent upon available resources.
- C. In order to be considered for readmission by the Admissions Committee, the applicant must meet current guidelines for admission to the College and the Physical Therapist Assistant program.
- D. Readmission may be contingent upon the candidate’s agreeing to audit previously completed course work.
- E. A student who applies for readmission to the Physical Therapist Assistant program must provide significant evidence that establishes the potential for future success in the program.

PTA Program Transfer Policy:

Applicants who wish to transfer from another PTA Program to

the GCSC PTA Program must 1) meet all current admission requirements, 2) apply by the application deadline prior to the fall semester they wish to enter, 3) notify the coordinator in writing, stating anticipated entry date and reason for transfer, 4) provide evidence of successful completion of previous core PTA courses from a CAPTE accredited program, and 5) provide a letter from the program chair stating that the student is in good academic/clinical standing and is eligible to return to the PTA program they wish to transfer from. Acceptance of any transfer student will be dependent upon available resources.

Transferability of GCSC PTA courses to another institution will be dependent upon acceptance of the receiving institution.

Curriculum Detail

Course Number	Course Name/Course Area	Credit Hours
Communications Area – 3 credit hours		
ENC1101 OR ENC1101C	English Composition I OR Enhanced English Composition	3
Humanities Area – 3 credit hours		
	Visual & Performing Arts OR Philosophy/Religion OR Literature	3
Mathematics Area – 3 credit hours		
*	College-level mathematics	3
Natural Sciences Area – 8 credit hours		
BSC2085*	Anatomy & Physiology I	3
BSC2085L*	Anatomy & Physiology I Lab	1
BSC2086	Anatomy & Physiology II	3
BSC2086L	Anatomy & Physiology II Lab	1
Social Sciences Area – 6 credit hours		
PSY2012	General Psychology	3
POS2041 OR AMH2020	American National Government OR US History	3
Major Courses – 51 credit hours		
HSC1531	Medical Terminology	2
PHT1000	Introduction to Physical Therapy	2
PHT1102	Applied Anatomy for PTAs	2
PHT1102L	Applied Anatomy Lab for PTAs	1
PHY1200	Basic Skills in Patient Care	2
PHT1200L	Basic Skills in Patient Care Lab	2
PHT1124	Functional Human Motion	2
PHT1124	Functional Human Motion Lab	1
PHT1131	Assessment, Measurement & Documentation	1
PHT1131L	Assessment, Measurement & Documentation Lab	2
PHT1220	Introduction to Therapeutic Exercise	3
PHT1220L	Introduction to Therapeutic Exercise Lab	2

PHT2224	Therapeutic Interventions I: Medical/Surgical Disabilities	2
PHT2224L	Therapeutic Interventions I Lab	1
PHT2211	Therapeutic Modalities	2
PHT2211L	Therapeutic Modalities Lab	2
PHT2225	Therapeutic Interventions II: Orthopedic Disabilities	3
PHT2225L	Therapeutic Interventions II Lab	2
PHT2226	Therapeutic Interventions III: Neurological Disabilities	3
PHT2226L	Therapeutic Interventions III Lab	2
PHT2801	PTA Clinical Practice I	2
PHT2810	PTA Clinical Practice II	4
PHT2820	PTA Clinical Practice III	4
PHT2931	Seminar	2
TOTAL DEGREE HOURS		74

*Milestone Courses

Radiography (RAD2-AS)

AREA OF CONCENTRATION: The purpose of this program is to prepare students to become registered radiographers, following successful completion of the prescribed courses of study and clinical practice. Graduates who pass the American Registry of Radiologic Technologist's examination will be eligible to work as radiographers in various health care facilities such as hospitals, doctors' offices and sports medicine clinics. The duration of the program is approximately 21 months. Courses must be completed in the prescribed sequence. In addition to general education requirements, student will learn to safely perform diagnostic radiographic examinations. **This is a Limited Access Program.**

The Radiography program is a limited access program. A selective admissions policy with specific selection criteria is utilized in order to select the most qualified applicants. The strength of the applicant pool varies year-to-year, with the best qualified applicants receiving first consideration. It is the applicant's responsibility to inquire about these specific admission and selection criteria and to ensure that all required documents are received on campus prior to the second Friday in May as outlined in the application packet.

To apply for this program of study, students should obtain a program application packet from the Division of Health Sciences offices or on the college website, under Academics>Academic Divisions>Health Sciences

Program Coordinator: Lacy Newsom 850.913.3318

Professional Licensure Disclosure

Gulf Coast State College is approved to offer programs that may lead to professional licensure or certification in Florida.

GCSC does not guarantee that programs which fulfill Florida licensing requirements will satisfy the criteria of professional licensure boards in other states, as each state has unique requirements for professional licensure or certification which are subject to change at any time and without notice.

Enrolled students and prospective students are strongly encouraged to contact their state's licensure entity to review all licensure or certification requirements imposed by their state(s) of choice. Please review the licensing board for guidance on the professional licensure or certification requirements for programs in your home state or where you would like to practice professionally.

GCSC is required by the National Council for State Authorization Reciprocity Agreements (NC-SARA) to disclose whether your prospective program meets the professional licensure or certification requirements in other states. NC-SARA does not address professional licensure issues.
<https://gulfcoast.edu/academics/online/professional-licensure-disclosure.html>

PLEASE NOTE: Gulf Coast State College is not requiring a COVID-19 vaccination. However, students completing clinical/practicum experiences in agencies and clinical sites that bill patients under Medicare and Medicaid must be fully vaccinated against COVID-19 or have received an exemption according to the CMS Interim Final Rule. Gulf Coast State College Health Sciences students will be asked to report vaccination status (vaccinated or not vaccinated) to the program for clinical placement purposes. Exemptions to clinical site vaccination requirements will occur between the clinical site and the student because GCSC does not have a COVID-19 vaccination requirement.

Admission Requirements:

Application to the Radiography program includes:

- Apply to Gulf Coast State College. General admission to the college must be granted prior to applying to the Radiography program. General admission to Gulf Coast State College **does not** imply acceptance into the Radiography program.
- Submit program application form including the Technical Standards form
- Completion of MAC1105 or equivalent, BSC2085, BSC2085L, BSC2086, and BSC2086L with a grade of "C" or better
- Cumulative Grade Point Average (GPA) of 2.5 or higher
- Submit official high school transcript or GED transcript to the Office of Enrollment Services
- Submit all official college transcripts to the Office of Enrollment Services for evaluation prior to the application deadline

The program begins in the fall semester each year. The deadline for submission of the completed application package is the second Friday in May. The program employs a selective admission process whereby applicants are chosen based on a composite admissions score. Applicants who meet all minimum requirements for admission are evaluated for their preparedness to enter the program. The following areas are considered:

- Final course grades in MAC1105 or equivalent, BSC2085, BSC2085L, BSC2086, and BSC2086L
- Cumulative GPA on all course work completed
- Enhancement Points: Health care work experience with direct patient care, letters of recommendation, completion of PHY1020, and/or SLS1201 with a grade of "C" or higher and all other general education requirements.

Program policies regarding transfer, retention, dismissal, and readmission of students are found in the *Radiography Student Handbook*. The handbook can be found on the Radiography Program's webpage.

Requirements after conditional acceptance:

- A. Satisfactory fingerprint/criminal background check through Gulf Coast State College
- B. Current CPR certification from the American Heart Association Health Care Provider Basic Life Support Course
- C. Satisfactory completion of a physical examination signed a physician or primary healthcare provider
- D. Current immunization records to include Hepatitis B series or signed waiver and TB test according to program requirements.
- E. Completion of the Healthcare Interprofessional Training course that includes: Domestic Violence, HIPAA, HIV/Aids-2 hrs., Hospital Orientation, Human Trafficking, Infection Control, Interprofessional Education (IPE), Prevention of Medical Errors, and Airborne Precautions w/Mask Fit.

Curriculum Detail

Course Number	Course Name/Course Area	Credit Hours
Communications Area – 3 credit hours		
ENC1101 OR ENC1101C	English Composition I OR Enhanced English Composition	3
Humanities Area – 3 credit hours		
General Education Core Course	Visual & Performing Arts OR Philosophy/Religion OR Literature	3
Mathematics Area – 3 credit hours		
*	College-level mathematics	3
Natural Sciences Area – 3 credit hours		
BSC2085*	Anatomy & Physiology I	3
BSC2085L*	Anatomy & Physiology I Lab	1

BSC2086	Anatomy & Physiology II	3
BSC2086L	Anatomy & Physiology II Lab	1
Social Sciences Area – 3 credit hours		
POS2041 OR AMH2020	American National Government OR US History II	3
Major Courses – 57 credit hours		
RTE1000	Introduction to Diagnostic Imaging	2
RTE111C	Introduction to Patient Care	2
RTE1503	Radiographic Procedures/Positioning I	3
RTE1503L	Radiographic Procedures/Positioning I Lab	1
RTE1804	Clinical Education I	3
RTE1418	Principles of Radiographic Exposure I	3
RTE1513	Radiographic Procedures/Positioning II	3
RTE1513L	Radiographic Procedures/Positioning II Lab	1
RTE1814	Clinical Education II	3
RTE1457	Principles of Radiographic Exposure II	4
RTE1523	Radiographic Procedures/Positioning III	2
RTE1523L	Radiographic Procedures/Positioning III Lab	1
RTE1824	Clinical Education III	4
RTE2385	Radiobiology & Radiation Protection	3
RTE2782	Radiographic Pathology	2
RTE2834	Clinical Education IV	5
RTE2563	Advanced Medical Imaging	3
RTE2844	Clinical Education V	5
RTE2061	Radiography Seminar	2
HSC1531	Medical Terminology	2
CGS1570	Microcomputer Applications	3
TOTAL DEGREE HOURS		77

*Milestone Courses

Respiratory Care (RESP-AS)

AREA OF CONCENTRATION: The purpose of this program is to prepare students to become registered respiratory therapists by obtaining the National Board of Respiratory Care (RRT) credential. Respiratory therapists are employed in hospitals, rehabilitation facilities, sleep disorder clinics, pulmonary function labs, hyperbaric chambers, skilled nursing facilities, and home health agencies. **This is a Limited Access Program.**

Gulf Coast State College Respiratory Care Program (CoARC #200449) is fully accredited by the Commission on Accreditation for Respiratory Care (CoARC).

Program Coordinator: Jennifer Barber 850.872.3837

To apply for this program of study, students should obtain a program application packet from the Division of Health Sciences offices or on the college website, under Academics>Academic Divisions>Health Sciences.

Professional Licensure Disclosure

Gulf Coast State College is approved to offer programs that may lead to professional licensure or certification in Florida. GCSC does not guarantee that programs which fulfill Florida licensing requirements will satisfy the criteria of professional licensure boards in other states, as each state has unique requirements for professional licensure or certification which are subject to change at any time and without notice.

Enrolled students and prospective students are strongly encouraged to contact their state's licensure entity to review all licensure or certification requirements imposed by their state(s) of choice. Please review the licensing board for guidance on the professional licensure or certification requirements for programs in your home state or where you would like to practice professionally.

GCSC is required by the National Council for State Authorization Reciprocity Agreements (NC-SARA) to disclose whether your prospective program meets the professional licensure or certification requirements in other states. NC-SARA does not address professional licensure issues. <https://gulfcoast.edu/academics/online/professional-licensure-disclosure.html>

PLEASE NOTE: Gulf Coast State College is not requiring a COVID-19 vaccination. However, students completing clinical/practicum experiences in agencies and clinical sites that bill patients under Medicare and Medicaid must be fully vaccinated against COVID-19 or have received an exemption according to the CMS Interim Final Rule. Gulf Coast State College Health Sciences students will be asked to report vaccination status (vaccinated or not vaccinated) to the program for clinical placement purposes. Exemptions to clinical site vaccination requirements will occur between the

clinical site and the student because GCSC does not have a COVID-19 vaccination requirement.

In accordance with 34 C.F.R. § 668.43, GCSC has determined the Respiratory Care program meets the educational licensure requirements for all 50 states, the District of Columbia, and the US protectorates, as defined in 34 C.F.R. § 600.2.

It is strongly encouraged that students, applicants, and prospective students determine any additional requirements for licensure in the State in which they seek to be licensed. Information regarding State licensure can be found at: <https://practitionerportal.nbrc.org/licensure/list>

If you need assistance or have any questions, please contact Jennifer Barber at jbarber@gulfcoast.edu or 850-872-3837

Selection: Applications are accepted throughout the year. Consideration for acceptance will begin in January and continue until the class is filled. New classes begin in the fall of each year.

The application deadline is the first business day in June; the respiratory care program accepts up to twenty students per year. There are no course prerequisites for acceptance into the program but preference is given to those students having completed Anatomy and Physiology courses and other general education courses required to receive an Associates of Science Degree.

Preference: Applicants having completed any of the following courses with a "C" or better will have selection preference: BSC2085, BSC2085L, BSC2086, BSC2086L, and HSC1531.

ADMISSION PROCESS:

The Respiratory Care program is a limited access program. A selective admissions policy with specific selection criteria is utilized in order to select the most qualified applicants. The strength of the applicant pool varies year-to-year, with the highest qualified applicants receiving first consideration. It is the applicant's responsibility to inquire about these specific admission and selection criteria and to ensure that all required documents are received on campus prior to the deadline published in the application packet.

Provisional Admission Requirements:

- A. Apply to Gulf Coast State College. General admission to the college must be granted prior to applying to the Respiratory Care program. General admission to Gulf Coast State College **does not** imply acceptance into the Respiratory Care program.
- B. Official high school transcript or GED and all official transcripts sent to Enrollment Services for evaluation
- C. Demonstration of math/algebra, English and reading competency via current (within 2 years) CPT/PERT scores or ACT/SAT equivalent. Approved college-level courses in

math/algebra, and English may also satisfy competency requirements.

D. Application to the Respiratory Care Program, including:

1. Respiratory Care application
2. Core Performance Standards for Admission and Progression
3. Discussion "Why are you interested in becoming a Respiratory Therapist"
4. Additional documentation if applicable (as specified in application packet)

Requirements after Provisional Acceptance:

A. Completion of prerequisites courses with a grade of "C" or better prior to First Year Fall-Term 2

1. BSC2085, Anatomy & Physiology I
2. BSC2085L, Anatomy & Physiology I Lab
3. ENC1101 OR ENC1101C, English Composition or Enhanced English Composition
4. College-level Math

B. Report of Vaccination History to include:

1. Hepatitis B Surface Antigen test
2. Hepatitis B vaccine series, if surface antigen is positive (or signed declination waiver)
3. PPD Mantoux/TB Test (may require chest radiograph if previously positive PPD Mantoux/TB test)
4. MMR (Measles, Mumps, Rubella)
5. Varicella (Chickenpox)
6. Tetanus-Diphtheria (Tetanus every 10 years)

C. Copy of current Cardiopulmonary Resuscitation (CPR) certificate (BLS for Healthcare Providers) by the AHA

D. Satisfactory fingerprint/criminal background check

E. Healthcare Interprofessional Training (every 2 years)

1. HIPAA
2. HIV/AIDS
3. Prevention of Medical Errors
4. Domestic Violence
5. Infection Control Training
6. Interprofessional Education
7. Airborne Precautions w/Mask Fit
8. Hospital orientation

F. Satisfactory physical examination (Signed by physician/HCP)

G. Satisfactory drug screening results

3. Readmission to the Respiratory Care Program will be dependent upon available resources.

4. In order to be considered for readmission by the Admissions Committee, the applicant must do the following:

- a. Submit a written request letter (not e-mail) to the Respiratory Care Coordinator/ Program Director presenting evidence to justify readmission.
- b. Meet current guidelines for admission to the College and the Respiratory Care Program.

5. Readmission may be contingent upon the candidate's agreeing to audit previously completed course work. Students may not be readmitted to the last semester they attend.

6. A student who applies for readmission to the Respiratory Care Program must provide significant evidence, which suggests the potential for future success in the program. This evidence may address such things as unusual circumstances, remedial study, and/or additional preparation.

Respiratory Care Transfer Policy:

Applicants who wish to transfer from another Respiratory Care Program to a GCSC Respiratory Care Program must:

1. Meet all current admission requirements
2. Apply at least two months prior to the expected date of enrollment
3. Notify the Program Director/Coordinator in writing, stating anticipated entry date and reason for transfer
4. Provide evidence of successful completion of previous core Respiratory Care courses from a CoARC accredited program, and
5. Provide a letter from the Program Director stating that the student is in good academic and clinical standing and is eligible to return to the Respiratory Care program they wish to transfer from.

Acceptance of any transfer student will be dependent upon available resources.

Transferability of GCSC Respiratory Care courses to another institution will be dependent upon the acceptance of the receiving institution.

Readmission Guidelines:

1. A student who withdraws from or earns a grade lower than a "C" in any RET course will not be permitted to continue in the Respiratory Care Program. A student who does not meet the Technical Standards of the program will not be permitted to continue in the program.
2. Applicants who wish to apply for readmission should do so prior to March 1 if planning to enroll in the fall semester.

Curriculum Detail

Course Number	Course Name/Course Area	Credit Hours
Communications Area – 3 credit hours		
ENC1101 OR ENC1101C	English Composition I OR Enhanced English Composition	3
Humanities Area – 3 credit hours		
	Visual & Performing Arts OR Philosophy/Religion OR Literature	3
Mathematics Area – 3 credit hours		
*	College-level mathematics	3
Natural Sciences Area – 8 credit hours		
BSC2085*	Anatomy & Physiology I	3
BSC2085L*	Anatomy & Physiology I Lab	1
BSC2086	Anatomy & Physiology II	3
BSC2086L	Anatomy & Physiology II Lab	1
Social Sciences Area – 6 credit hours		
PSY2012 or SYG2000	General Psychology or Introduction to Sociology	3
POS2041 OR AMH2020	American National Government OR US History II	3
Major Courses – 56 credit hours		
HSC1531	Medical Terminology	2
RET1005	Management of Cardiopulmonary Microbiology & Disorders	3
RET1024	Respiratory Care I	3
RET1024L	Respiratory Care I Lab	2
RET1264	Respiratory Care II	3
RET1264L	Respiratory Care II Lab	2
RET1400	Cardiopulmonary Procedures	3
RET1483	Cardiopulmonary Assessment	3
RET1485	Cardiopulmonary Anatomy & Physiology	3
RET1832	Respiratory Care Clinical I	1
RET1833	Respiratory Care Clinical II	2
RET1934	Selected Topics Seminar	1
RET2007	Cardiopulmonary Pharmacology	3
RET2280	Respiratory Care IV	3
RET2280L	Respiratory Care IV Lab	2
RET2714	Respiratory Care V	3
RET2714L	Respiratory Care V Lab	2
RET2834	Respiratory Care Clinical III	2
RET2835	Respiratory Care Clinical IV	2
RET2836	Respiratory Care Clinical V	3
RET2878	Respiratory Care III	3
RET2878L	Respiratory Care III Lab	2
TOTAL DEGREE HOURS		76

*Milestone Courses

Respiratory Care, Liberal Arts Option (RET-AA)

AREA OF CONCENTRATION: The purpose of this university transfer track is to prepare students to enter a baccalaureate cardiopulmonary science degree at a university. **Completing this AA option will NOT result in eligibility to sit for a licensing exam to become a registered respiratory therapist.** Please refer to the AS degree option for Respiratory Care should that be your goal at GCSC.

Faculty Advisor: Jennifer Barber 850.872.3837

Curriculum Detail

Course Number	Course Name/Course Area	Credit Hours
Communications Area – 6 credit hours		
ENC1101 OR ENC1101C	English Composition I OR Enhanced English Composition	3
ENC1102	English Composition II	3
Humanities Area – 9 credit hours		
	Visual and Performing Arts	3
	Philosophy/Religion	3
	Literature	3
Mathematics Area – 6 credit hours		
MAC1114*	Plane Trigonometry	3
MAC1140*	Pre-Calculus Algebra	3
Natural Sciences Area – 6 credit hours		
PHY2053	College Physics I	3
BSC2085*	Anatomy & Physiology I	3
Social Sciences Area – 9 credit hours		
	Behavioral Science	3
	History	3
	Government	3
Transfer Common Prerequisites – 15 credit hours		
BSC2085L	Anatomy & Physiology I Lab	1
BSC2086	Anatomy & Physiology II	3
BSC2086L	Anatomy & Physiology II Lab	1
HUN1201	Principles of Nutrition	3
MCB2004	Microbiology	3
MCB2004L	Microbiology Lab	1
PHY2053L	College Physics I Lab	1
BSC2010	Biology for Science Majors I	3
BSC2010L	Biology for Science Majors I Lab	1
CHM1045	General Chemistry	3
CHM1045L	General Chemistry Lab	1
SPC1608	Introduction to Public Speaking	3
CGS1570	Microcomputer Applications	3
TOTAL DEGREE HOURS		60

*Milestone Courses

Sonography, Diagnostic Medical (DMS-AS)

AREA OF CONCENTRATION: The program is designed to prepare the student for employment as an entry-level sonographer. The sonographer is skilled by academic and clinical training to perform ultrasound examinations under the supervision of a qualified physician. Students should complete all prerequisite courses. Students are strongly encouraged to complete as many of the general education courses as possible **prior** to seeking admission to the Diagnostic Medical Sonography program. **This is a Limited Access Program.**

The program curriculum includes all courses required for an Associate in Science Degree. A minimum grade of “C” must be achieved in all prerequisite courses required for program admission. The program begins in January of the spring semester each year. The duration of the program is 24 months for the Associate in Science Degree (77 credit hours). The Diagnostic Medical Sonography program is accredited by the Southern Association of Colleges and Schools and follows the Florida Department of Education curriculum frameworks for Diagnostic Medical Sonography Technology-AS.

The Diagnostic Medical Sonography program is a limited access program. A selective admissions policy with specific selection criteria is utilized in order to select the most qualified applicants. All applicants who meet the minimum requirements for admission are evaluated by the Selection Committee. The strength of the applicant pool varies year-to-year, with the best qualified applicants receiving first consideration. It is the applicant’s responsibility to inquire about these specific admission and selection criteria and to ensure that all required documents are received on campus prior to the deadline in September as published in the application packet.

To apply for this program of study, students should obtain a program application packet from the Division of Health Sciences offices or on the college website, under Academics>Academic Divisions>Health Sciences

Program Coordinator: Janice Skipper 850.769.1551 x3390

Professional Licensure Disclosure

Gulf Coast State College is approved to offer programs that may lead to professional licensure or certification in Florida. GCSC does not guarantee that programs which fulfill Florida licensing requirements will satisfy the criteria of professional licensure boards in other states, as each state has unique requirements for professional licensure or certification which are subject to change at any time and without notice.

Enrolled students and prospective students are strongly encouraged to contact their state’s licensure entity to review all licensure or certification requirements imposed by their

state(s) of choice. Please review the licensing board for guidance on the professional licensure or certification requirements for programs in your home state or where you would like to practice professionally.

GCSC is required by the National Council for State Authorization Reciprocity Agreements (NC-SARA) to disclose whether your prospective program meets the professional licensure or certification requirements in other states. NC-SARA does not address professional licensure issues.
<https://gulfcoast.edu/academics/online/professional-licensure-disclosure.html>

PLEASE NOTE: Gulf Coast State College is not requiring a COVID-19 vaccination. However, students completing clinical/practicum experiences in agencies and clinical sites that bill patients under Medicare and Medicaid must be fully vaccinated against COVID-19 or have received an exemption according to the CMS Interim Final Rule. Gulf Coast State College Health Sciences students will be asked to report vaccination status (vaccinated or not vaccinated) to the program for clinical placement purposes. Exemptions to clinical site vaccination requirements will occur between the clinical site and the student because GCSC does not have a COVID-19 vaccination requirement.

After being accepted to the Diagnostic Medical Sonography Program, the courses in the curriculum are progressive in nature, with one course building on the preceding course. Because of this progressive relationship, all courses in a term must be completed with a grade of “C” (70) or better in order to continue to the next term. If a student achieves less than a “C” (70) or withdraws from any course that is required for the Associate in Science Degree, the student will not be allowed to continue in the program. The student may re-apply to the program according to the readmission guidelines.

Application Requirements:

- A. Apply to Gulf Coast State College. General admission to the college must be granted prior to applying to the Sonography, Diagnostic Medical program. General admission to Gulf Coast State College **does not** imply acceptance into the Sonography, Diagnostic Medical program.
- B. Official high school transcripts or GED and all official college transcripts sent to Enrollment Services for evaluation prior to the application deadline.
- C. Overall Grade Point Average (GPA) of 2.5 or higher
- D. Complete with a “C” or higher, the following prerequisites: BSC2085 Anatomy and Physiology I, BSC2085L, Anatomy and Physiology I Lab, ENC1101,

- English Composition and PHY1020, Basic Concepts of Physics or Approved Physics.
- E. Application to Diagnostic Medical Sonography (DMS) program including:
1. DMS-AS application
 2. Technical Standards Form
 3. Observation Documentation Form
 4. Healthcare Work Experience Form (if applicable)
 5. Additional documentation if applicable (as specified in the application packet)

Requirements after conditional acceptance:

1. Report of Vaccination History to include:
 - Hepatitis B Surface Antigen test
 - Hepatitis B vaccine series, if surface antigen is positive (or signed declination waiver)
 - PPD Mantoux/TB Test (may require chest radiograph if previously positive PPD Mantoux/TB test)
 - MMR (Measles, Mumps, Rubella)
 - Varicella (Chickenpox)
 - Tetanus-Diphtheria (Tetanus every 10 years)
 - Influenza (or signed declination waiver)
2. Copy of current Cardiopulmonary Resuscitation (CPR) certificate (BLS for Healthcare Providers) by the AHA
3. Satisfactory fingerprint/criminal background check
4. Healthcare Interprofessional Training (every 2 years)
 - HIPAA
 - HIV/AIDS
 - Prevention of Medical Errors
 - Domestic Violence
 - Infection Control
 - Human Trafficking
 - Interprofessional Education
 - Airborne Precautions w/Mask Fit
5. Satisfactory physical examination (signed by licensed physician/health care provider)
6. Satisfactory drug screening results

Readmission guidelines:

1. Readmission to the DMS Program will be dependent upon available resources.
2. A student who withdraws from or earns a grade lower than a "C" (70) in one of the approved science courses and/or in a DMS Program course will not be permitted to continue in the DMS Program. A student who does not meet the Technical Standards of the program will not be permitted to continue in the program.
3. A student who applies for readmission to the DMS Program must provide significant evidence which suggests the potential for future success in the program. This evidence may address such things as unusual circumstances, remedial study, and/or additional preparation.
4. In order to be considered for readmission by the Selection Committee, the student must do the following no less than two months prior to the semester they

withdrew/dropped to allow sufficient time for reevaluation:

- a. Submit a written request letter (not an e-mail) to the Diagnostic Medical Sonography Program Coordinator presenting evidence to justify readmission. This may include evidence suggested in guideline 3 (above), letters of recommendation from a previous faculty member or coordinator, additional course work, work experience, etc.
 - b. Meet current guidelines for admission to the College and the DMS Program.
5. Readmission may be contingent upon the applicant agreeing to audit previously completed course work as deemed necessary.

Transfer Policy:

Acceptance of any transfer student will be dependent upon available resources. Applicants who wish to transfer from another DMS Program to GCSC Diagnostic Medical Sonography Program must:

1. Meet all current admission requirements to the College and the DMS Program listed above under Application Requirements and Requirements after conditional acceptance.
2. Apply at least two months prior to expected date of enrollment.
3. Notify the Diagnostic Medical Sonography Program Coordinator in writing, stating anticipated entry date and reason for transfer.
4. Provide evidence of successful completion of previous core sonography courses with grades of "C" (70) or higher from an accredited program.
5. Provide a letter from the previous Program Director stating that the student is in good academic and clinical standing and is eligible to return to the DMS Program from which they wish to transfer.

*Transferability of GCSC Diagnostic Medical Sonography courses to another institution will be dependent on acceptance by the receiving institution.

Course Audit Expectations:

Course completion and attendance guidelines are the same for students taking any SON course for a grade, pass-fail or audit. Failure to meet all course requirements as outlined in the syllabus will result in the student not being permitted to continue in the DMS Program.

Curriculum Detail

Course Number	Course Name/Course Area	Credit Hours
Prerequisite Courses		
Communications Area – 3 credit hours		
ENC1101 OR ENC1101C	English Composition I OR Enhanced English Composition	3

Natural Sciences Area – 7 credit hours		
BSC2085*	Anatomy & Physiology I	3
BSC2085L*	Anatomy & Physiology I Lab	1
PHY1020*	Basic Concepts of Physics	3
Humanities Area – 3 credit hours		
	Visual & Performing Arts OR Philosophy/Religion OR Literature	3
Mathematics Area – 3 credit hours		
*	College-level mathematics	3
Social Sciences Area – 3 credit hours		
POS2041 OR AMH2020	American National Government OR US History II	3
Major Courses – 58 credit hours		
BSC2086	Anatomy & Physiology II	3
BSC2086L	Anatomy & Physiology II Lab	1
SON1211	Medical Sonography Physics	3
SON1000	Introduction to Sonography	1
SON1100	Principles & Protocols of Sonography Imaging	2
SON1170	Sonography Circulatory System	2
SON1214	Practical Aspects of Sonography	1
SON2171	Introduction to Vascular Sonography	3
SON2175	Vascular Sonography	3
SON1111	Abdominal Sonography I	3
SON1112	Abdominal Sonography II	3
SON1121	OB/GYN Sonography I	3
SON1122	OB/GYN Sonography II	3
SON1052	Sonography & Pathology	4
SON1144	Superficial Structures	1
SON2113	Sono Cross Sectional Anatomy	3
SON1804	Clinical Education I	1
SON1814	Clinical Education II	3
SON1824	Clinical Education III	4
SON2834	Clinical Education IV	4
SON2844	Clinical Education V	5
SON2061	Sonography Review	2
TOTAL DEGREE HOURS		77

***Milestone Courses**

Surgical First Assisting Associate in Science (SFA2-AS)

AREA OF CONCENTRATION: The purpose of this 25-month, seven-semester, dual certification program is to promote knowledge based critical thinking in safe practice and educate students in the specialty of surgical first assisting and surgical technology as an entry level surgical technologist and surgical first assistant. Upon completion of all graduation requirements, graduates of this program will receive an Associate in Science degree in Surgical First Assisting. Successful completion of the program will allow graduates to apply to take the national certifying examination provided all the eligibility requirements currently established are met.

This is a Limited Access Program.

This degree is also available to practicing Certified Surgical Technologists (CST) credentialed by the National Board of Surgical Technology and Surgical Assisting (NBSTSA).

To apply for this program of study, students should obtain a program application packet from the Division of Health Sciences offices or on the college website, under Academics>Academic Divisions>Health Sciences

Program Coordinator: Shannon Smith 850.769.1551

Professional Licensure Disclosure

Gulf Coast State College is approved to offer programs that may lead to professional licensure or certification in Florida. GCSC does not guarantee that programs which fulfill Florida licensing requirements will satisfy the criteria of professional licensure boards in other states, as each state has unique requirements for professional licensure or certification which are subject to change at any time and without notice.

Enrolled students and prospective students are strongly encouraged to contact their state's licensure entity to review all licensure or certification requirements imposed by their state(s) of choice. Please review the licensing board for guidance on the professional licensure or certification requirements for programs in your home state or where you would like to practice professionally.

GCSC is required by the National Council for State Authorization Reciprocity Agreements (NC-SARA) to disclose whether your prospective program meets the professional licensure or certification requirements in other states. NC-SARA does not address professional licensure issues. <https://gulfcost.edu/academics/online/professional-licensure-disclosure.html>

PLEASE NOTE: Gulf Coast State College is not requiring a COVID-19 vaccination. However, students completing clinical/practicum experiences in agencies and clinical sites that bill patients under Medicare and Medicaid must be fully vaccinated against COVID-19 or have received an exemption

according to the CMS Interim Final Rule. Gulf Coast State College Health Sciences students will be asked to report vaccination status (vaccinated or not vaccinated) to the program for clinical placement purposes. Exemptions to clinical site vaccination requirements will occur between the clinical site and the student because GCSC does not have a COVID-19 vaccination requirement.

APPLICATION REQUIREMENTS:

- A. General admission to the college must be granted prior to applying to the Surgical First Assisting program. General admission to Gulf Coast State College **does not** imply acceptance into the Surgical First Assisting program. Application to Gulf Coast State College.
- B. Official high school transcript or GED and all official college transcript(s) sent to Enrollment Services for evaluation
- C. Demonstration of Math/Algebra, English and Reading Competency via current (within 2 years) CPT/PERT scores or ACT/SAT equivalent. Approved college-level courses in Math/Algebra, English, and Reading may also satisfy competency requirements
- D. Application to the Surgical First Assisting AS program including:
 1. SFA2-AS application
 2. Technical Standards form
 3. Two reference forms
 4. Additional documentation if applicable (as specified in the application packet)
- E. Complete a transcript analysis with Enrollment Services and the course program coordinator

Requirements after provisional acceptance:

- A. Completion of BSC2085 and BSC2085L with a grade of "C" or better and BSC2086 and BSC2086L or currently enrolled
- B. Report of Vaccination History to include:
 1. Hepatitis B Surface Antigen test
 2. Hepatitis B vaccine series, if surface antigen is positive (or signed declination waiver)
 3. PPD Mantoux/TB Test (may require chest radiograph if previously positive PPD Mantoux/TB test)
 4. MMR (Measles, Mumps, Rubella)
 5. Varicella (Chickenpox)
 6. Tetanus-Diphtheria (Tetanus every 10 years)
- C. Copy of current Cardiopulmonary Resuscitation (CPR) certificate (BLS for Healthcare Providers) by the AHA
- D. Satisfactory fingerprint/criminal background check
- E. Healthcare Interprofessional Training (every 2 years)
 1. HIPAA
 2. HIV/AIDS
 3. Prevention of Medical Errors
 4. Domestic Violence
 5. Infection Control
 6. Human Trafficking
 7. Interprofessional Education
 8. Airborne Precautions w/Mask Fit

- F. Satisfactory physical examination (signed by physician/health care provider)
- G. Satisfactory drug screening results

ADMISSIONS:

The Surgical First Assisting A.S. degree program is a limited access program. A selective admissions policy with specific selection criteria is utilized in order to select the most qualified applicants. The strength of the applicant pool varies year-to-year, with the highest qualified applicants receiving first consideration. It is the applicant's responsibility to inquire about these specific admission and selection criteria and to ensure that all required documents are received on campus prior to the deadline published in the current application packet. Students who are validated as currently certified as a surgical technologist (CST) may apply for entry as outlined in the current application packet.

GCSC Articulation:

If you are a NBSTSA Certified Surgical Technologist (CST), up to 45 of previous CST college credits (classroom, lab skills and clinical experience) may be awarded by submission of the external packet which must include proof of current NBSTSA certification as a surgical technologist (CST).

To be eligible to graduate from GCSC, the student will have to complete at least 25% of the entire 74 credit program with Gulf Coast State College which is a minimum of 19 credit hours completed at GCSC for the SFA2-AS degree.

Professional Licensure: If applicants or students are earning an online degree while residing outside the state of Florida, Gulf Coast State College will provide them with current contact information for any applicable licensing boards and will help them determine whether the program meets requirements for licensure in the state where they are located.

Graduation and Retention Requirements: For the Surgical First Assistant A.S. program, students must earn a grade of "C" or higher in each course. See Surgical Services Student Handbook for further information regarding graduation, retention, dismissal, readmission, and transfer credit policies.

Curriculum Detail

Course Number	Course Name/Course Area	Credit Hours
Communications Area – 3 credit hours		
ENC1101 OR ENC1101C	English Composition I OR Enhanced English Composition	3
Humanities Area – 3 credit hours		
	Visual & Performing Arts, Philosophy/Religion, OR Literature Biomedical Ethics Recommended	3
Mathematics Area – 3 credit hours		
	College-level mathematics	3
Natural Sciences Area – 8 credit hours		
BSC2085*	Anatomy & Physiology I	3
BSC2085L	Anatomy & Physiology I Lab	1
BSC2086	Anatomy & Physiology II	3
BSC2086L	Anatomy & Physiology II Lab	1
Social Sciences Area – 6 credit hours		
PSY2012 or SYG2000	General Psychology or Introduction to Sociology	3
POS2041 OR AMH2020	American National Government OR US History II	3
Prerequisite Coursework - 9 credit hours		
HSC1000	Orientation to Perioperative Services	3
HSC1000L	Orientation to Perioperative Services Lab	1
HSC1531	Medical Terminology	2
HSC2520*	Microbiology for Perioperative Services	3
Major Courses – 45 credit hours		
STS1310	Surgical Tech & Procedures	5
STS1310L	Surgical Tech & Procedures Lab	2
STS1340C	Pharmacology & Anesthesia	3
STS1940C	Introduction to Surgery Clinical	2
STS2323	Surgical Procedures I	4
STS2323L	Surgical Simulation I Lab	1
STS2324	Surgical Procedures II	3
STS2324L	Surgical Simulation II Lab	1
STS2330C	Principles of Surgical Assisting	2
STS2335	Advanced Integrated Surgical Sciences	2
STS2336	Advanced Surgical Procedures for the Surgical Assistant	2
STS2361	The Art of Teamwork in Surgery	1
STS2365	Professional Skills for the OR Team	1
STS2370	Surgical Assisting Clinical	2
STS2936	Surgical Certification Symposium	1
STS2944C	Surgical Clinical I	3
STS2945C	Surgical Clinical II	3

STS2953	Surgical Technologist Portfolio I	1
STS2954	Surgical Technologist Portfolio II	1
STS2366C Or STS2367	Surgical Assistant Professional Skills Or Management in Healthcare	2
TOTAL DEGREE HOURS		74

*Milestone Courses

Surgical First Assistant College Credit Certificate (SFA-CCC)

AREA OF CONCENTRATION: The purpose of this seven-semester, 24-month, 59 college credit program is to educate students in the specialty of Surgical First Assisting and promote knowledge based critical thinking in the safe practice of surgical technology as an entry level surgical technologist and surgical first assistant. Upon completion of all core graduation requirements, graduates of this program will receive a College Credit Certificate (CCC) as a Surgical First Assistant. Successful completion of the program will allow graduates to apply to take the national certifying examination provided all the eligibility requirements currently established are met. Students may choose to complete the requirements for an Associate of Science (AS) degree by completing the additional general education requirements. **This is a Limited Access Program.**

This college credit certificate is only available to those who are currently certified as a Certified Surgical Technologist (CST) by the National Board of Surgical Technology and Surgical Assisting (NBSTSA).

To apply for this program of study, students should obtain a program application packet from the Division of Health Sciences offices or on the college website, under Academics>Academic Divisions>Health Sciences

Program Coordinator: Shannon Smith 850.759.1551

Professional Licensure Disclosure

Gulf Coast State College is approved to offer programs that may lead to professional licensure or certification in Florida. GCSC does not guarantee that programs which fulfill Florida licensing requirements will satisfy the criteria of professional licensure boards in other states, as each state has unique requirements for professional licensure or certification which are subject to change at any time and without notice.

Enrolled students and prospective students are strongly encouraged to contact their state's licensure entity to review all licensure or certification requirements imposed by their state(s) of choice. Please review the licensing board for guidance on the professional licensure or certification requirements for programs in your home state or where you would like to practice professionally.

GCSC is required by the National Council for State Authorization Reciprocity Agreements (NC-SARA) to disclose whether your prospective program meets the professional licensure or certification requirements in other states. NC-SARA does not address professional licensure issues.
<https://gulfcoast.edu/academics/online/professional-licensure-disclosure.html>

PLEASE NOTE: Gulf Coast State College is not requiring a COVID-19 vaccination. However, students completing clinical/practicum experiences in agencies and clinical sites that bill patients under Medicare and Medicaid must be fully vaccinated against COVID-19 or have received an exemption according to the CMS Interim Final Rule. Gulf Coast State College Health Sciences students will be asked to report vaccination status (vaccinated or not vaccinated) to the program for clinical placement purposes. Exemptions to clinical site vaccination requirements will occur between the clinical site and the student because GCSC does not have a COVID-19 vaccination requirement.

APPLICATION REQUIREMENTS:

- A. Apply to Gulf Coast State College. General admission to the college must be granted prior to applying to the Surgical First Assistant program. General admission to Gulf Coast State College **does not** imply acceptance into the Surgical First Assistant program.
- B. Official high school transcript or GED and all official college transcript(s) sent to Enrollment Services for evaluation
- C. Complete a transcript analysis with Enrollment Services and the program coordinator
- D. Application to Surgical First Assistant CCC program, including:
 1. SFA-CCC application
 2. Technical Standards form
 3. Two reference forms
 4. Additional documentation if applicable (as specified in the Application Packet)

Requirements After Provisional Acceptance:

- A. Completion of BSC2085, BSC2085L, BSC2086, BSC2086L, HSC1531, HSC1000, HSC1001, and HSC2520 with a grade of "C" or better.
- B. Report of Vaccination History to include:
 - Hepatitis B Surface Antigen test
 - Hepatitis B vaccine series, if surface antigen is positive (or signed declination waiver)
 - PPD Mantoux/TB Test (may require chest radiograph if previously positive PPD Mantoux/TB test)
 - MMR (Measles, Mumps, Rubella)
 - Varicella (Chickenpox)
 - Tetanus-Diphtheria (Tetanus every 10 years)
- C. Copy of current Cardiopulmonary Resuscitation (CPR) certificate (BLS for Healthcare Providers) by the AHA
- D. Satisfactory fingerprint/criminal background check
- E. Healthcare Interprofessional Training (every 2 years)

- HIPAA
 - HIV/AIDS
 - Prevention of Medical Errors
 - Domestic Violence
 - Infection Control
 - Human Trafficking
 - Interprofessional Education
- F. Airborne Precautions w/Mask Fit Satisfactory physical examination (signed by licensed physician/health care provider)
- G. Satisfactory drug screening results

GCSC Articulation:

Up to 45 of the CST college credits (classroom, lab skills and clinical experience) may be awarded by submission of the external packet that includes a validated current nationally accredited credential such as proof of certification as a surgical technologist (CST). An associate in science degree is available by completing additional college credit courses (See SFA2-AS).

Professional Licensure: If applicants or students are earning an online degree while residing outside the state of Florida, Gulf Coast State College will provide them with current contact information for any applicable licensing boards and will help them determine whether the program meets requirements for licensure in the state where they are located.

Graduation and Retention Requirements: For the Surgical First Assistant CCC Program, students must earn a grade of "C" or higher in each course. See surgical services student handbook for further information regarding graduation, retention, dismissal, readmission, and transfer credit policies. To be eligible to graduate from GCSC, the student must complete at least 25% of the entire 59 credit program with Gulf Coast State College (a minimum of 15 credits must be taken at GCSC).

Curriculum Detail

Course Number	Course Name/Course Area	Credit Hours
Prerequisite Coursework - 17 credit hours		
BSC2085*	Anatomy & Physiology I	3
BSC2085L*	Anatomy & Physiology I Lab	1
BSC2086	Anatomy & Physiology II	3
BSC2086L	Anatomy & Physiology II Lab	1
HSC1000	Orientation to Perioperative Services	3
HSC1000L	Orientation to Perioperative Services Lab	1
HSC1531	Medical Terminology	2
HSC2520*	Microbiology for Perioperative Services	3
Major Courses – 42 credit hours		
STS1310	Surgical Tech & Procedures	5

STS1310L	Surgical Tech & Procedures Lab	2
STS1340C	Pharmacology & Anesthesia	3
STS1940C	Introduction to Surgery Clinical	2
STS2323	Surgical Procedures I	4
STS2323L	Surgical Simulation I Lab	1
STS2324	Surgical Procedures II	3
STS2324L	Surgical Simulation II Lab	1
STS2330C	Principles of Surgical Assisting	2
STS2335	Advanced Integrated Surgical Sciences	2
STS2336	Advanced Surgical Procedures for the Surgical Assistant	2
STS2361	The Art of Teamwork in Surgery	1
STS2365	Professional Skills for the OR Team	1
STS2370	Surgical Assisting Clinical	2
STS2936	Surgical Certification Symposium	1
STS2944C	Surgical Clinical I	3
STS2945C	Surgical Clinical II	3
STS2953	Surgical Technologist Portfolio I	1
STS2954	Surgical Technologist Portfolio II	1
STS2366C	Surgical Assistant Professional Skills	2
OR STS2367	OR Management in Healthcare	
TOTAL CERTIFICATE HOURS		59

Milestone Courses*Surgical Services Associate in Science (HS1-AS)**

AREA OF CONCENTRATION: The purpose of this 24-month, 64 college credit Associate in Science program is to educate students in the specialty of Surgical Technology and promote knowledge based critical thinking regarding safe healthcare practice. Upon completion of all graduation requirements, graduates of this program will receive an Associate in Science degree in Surgical Services (HS1-AS) with Surgical Technology Specialization. **This is a Limited Access Program.**

To apply for this program of study, students should obtain a program application packet from the Division of Health Sciences offices or on the college website, under Academics>Academic Divisions>Health Sciences

Program Coordinator: Shannon Smith 850.769.1551

Professional Licensure Disclosure

Gulf Coast State College is approved to offer programs that may lead to professional licensure or certification in Florida. GCSC does not guarantee that programs which fulfill Florida licensing requirements will satisfy the criteria of professional

licensure boards in other states, as each state has unique requirements for professional licensure or certification which are subject to change at any time and without notice.

Enrolled students and prospective students are strongly encouraged to contact their state's licensure entity to review all licensure or certification requirements imposed by their state(s) of choice. Please review the licensing board for guidance on the professional licensure or certification requirements for programs in your home state or where you would like to practice professionally.

GCSC is required by the National Council for State Authorization Reciprocity Agreements (NC-SARA) to disclose whether your prospective program meets the professional licensure or certification requirements in other states. NC-SARA does not address professional licensure issues. <https://gulfcost.edu/academics/online/professional-licensure-disclosure.html>

PLEASE NOTE: Gulf Coast State College is not requiring a COVID-19 vaccination. However, students completing clinical/practicum experiences in agencies and clinical sites that bill patients under Medicare and Medicaid must be fully vaccinated against COVID-19 or have received an exemption according to the CMS Interim Final Rule. Gulf Coast State College Health Sciences students will be asked to report vaccination status (vaccinated or not vaccinated) to the program for clinical placement purposes. Exemptions to clinical site vaccination requirements will occur between the clinical site and the student because GCSC does not have a COVID-19 vaccination requirement.

ADMISSIONS:

The Surgical Services A.S. degree program is a limited access program. A selective admissions policy with specific selection criteria is utilized in order to select the most qualified applicants. The strength of the applicant pool varies year-to-year, with the highest qualified applicants receiving first consideration. It is the applicant's responsibility to inquire about these specific admission and selection criteria and to ensure that all required documents are received on campus prior to the deadline published in the current application packet.

APPLICATION REQUIREMENTS:

- A. Apply to Gulf Coast State College. General admission to the college must be granted prior to applying to the Surgical Services program. General admission to Gulf Coast State College **does not** imply acceptance into the Surgical Services program.
- B. Official high school transcript or GED and all official college transcript(s) sent to Enrollment Services for evaluation
- C. Demonstration of Math/Algebra, English and Reading Competency via current (within 2 years) CPT/PERT

scores or ACT/SAT equivalent. Approved college-level courses in Math/Algebra, English, and Reading may also satisfy competency requirements

- D. Application to the Surgical Services A.S. degree program including:
 1. HS1-AS application
 2. Technical Standards form
 3. Two reference forms
 4. Additional documentation if applicable (as specified in the application packet)
- E. Complete a transcript analysis with Enrollment Services and the course program coordinator

Requirements after provisional acceptance:

- A. Submit proof of age – 18 years or older on or before the clinical start date for the applied class year
- B. Completion of BSC2085 and BSC2085L with a grade of "C" or better and BSC2086 and BSC2086L or currently enrolled
- C. Report of Vaccination History to include:
 1. Hepatitis B Surface Antigen test
 2. Hepatitis B vaccine series, if surface antigen is positive (or signed declination waiver)
 3. PPD Mantoux/TB Test (may require chest radiograph if previously positive PPD Mantoux/TB test)
 4. MMR (Measles, Mumps, Rubella)
 5. Varicella (Chickenpox)
 6. Tetanus-Diphtheria (Tetanus every 10 years)
- D. Copy of current Cardiopulmonary Resuscitation (CPR) certificate (BLS for Healthcare Providers) by the AHA
- E. Satisfactory fingerprint/criminal background check
- F. Interprofessional Healthcare Training (every 2 years)
 1. HIPAA
 2. HIV/AIDS
 3. Prevention of Medical Errors
 4. Domestic Violence
 5. Infection Control
 6. Human Trafficking
 7. Interprofessional Education
 8. Airborne Precautions w/Mask Fit
- G. Satisfactory physical examination (signed by licensed physician/health care provider)
- H. Satisfactory drug screening results

Graduation and Retention Requirements: For the Surgical Services program, students must earn a grade of "C" or higher in each required course. To be eligible to graduate from GCSC, the student must complete at least 25% of the entire 64 credit program (a minimum of 16 credits) at GCSC. See student handbook for further information regarding graduation, retention, dismissal, readmission, and transfer credit policies.

Curriculum Detail

Course Number	Course Name/Course Area	Credit Hours
Communications Area – 3 credit hours		
ENC1101 OR ENC1101C	English Composition I OR Enhanced English Composition	3
Humanities Area – 3 credit hours		
	Visual & Performing Arts OR Philosophy/Religion OR Literature	3
Mathematics Area – 3 credit hours		
	College-level mathematics	3
Natural Sciences Area – 3 credit hours		
BSC2085*	Anatomy & Physiology I	3
Social Sciences Area – 6 credit hours		
PSY2012 OR SYG2000	General Psychology OR Introduction to Sociology	3
POS2041 OR AMH2020	American National Government OR US History II	3
Prerequisite Coursework - 14 credit hours		
BSC2085L*	Anatomy & Physiology I Lab	1
HSC1000	Orientation to Perioperative Services	3
HSC1000L	Orientation to Perioperative Services Lab	1
HSC1531	Medical Terminology	2
HSC2520*	Microbiology for Perioperative Services	3
BSC2086	Anatomy & Physiology II	3
BSC2086L	Anatomy & Physiology II Lab	1
Major Courses – 32 credit hours		
STS1310	Surgical Tech & Procedures	5
STS1310L	Surgical Tech & Procedures Lab	2
STS1340C	Pharmacology & Anesthesia	3
STS1940C	Introduction to Surgery Clinical	2
STS2323	Surgical Procedures I	4
STS2323L	Surgical Simulation I Lab	1
STS2324	Surgical Procedures II	3
STS2324L	Surgical Simulation II Lab	1
STS2361	The Art of Teamwork in Surgery	1
STS2365	Professional Skills for the OR Team	1
STS2944C	Surgical Clinical I	3
STS2945C	Surgical Clinical II	3
STS2953	Surgical Technologist Portfolio I	1
STS2954	Surgical Technologist Portfolio II	1
STS2936	Surgical Certification Symposium	1
TOTAL DEGREE HOURS		64

*Milestone Courses

Central Sterile Processing Technologist College Credit Certificate (CSPT-CCC)

This College Credit Certificate is **only available to students currently enrolled in the Surgical Services Associate degree program (HS1-AS)**. Completion of the CSPT-CCC will permit the student to apply to take the national certifying examination provided all established current eligibility requirements are met.

AREA OF CONCENTRATION: The Central Sterile Processing Technologist CCC promotes knowledge based critical thinking regarding the safe practice of Central Sterile Processing. **This is a Limited Access Program.**

Program Coordinator: Shannon Smith 850.769.1551

Students who successfully complete two semesters of the Surgical Services Associate degree program (HS1-AS) with a grade of "C" or better in the following courses will be eligible to receive the Central Sterile Processing Technologist College Credit Certificate.

Curriculum Detail

Course Number	Course Name/Course Area	Credit Hours
Prerequisite Coursework - 17 credit hours		
BSC2085*	Anatomy & Physiology I	3
BSC2085L*	Anatomy & Physiology I Lab	1
BSC2086	Anatomy & Physiology II	3
BSC2086L	Anatomy & Physiology II Lab	1
HSC1000	Orientation to Perioperative Services	3
HSC1000L	Orientation to Perioperative Services Lab	1
HSC1531	Medical Terminology	2
HSC2520*	Microbiology for Perioperative Services	3
Major Courses – 13 credit hours		
STS1310	Surgical Tech & Procedures	5
STS1310L	Surgical Tech & Procedures Lab	2
STS1340C	Pharmacology & Anesthesia	3
STS1940C	Introduction to Surgery Clinical	2
STS2361	The Art of Teamwork in Surgery	1
TOTAL CERTIFICATE HOURS		30

*Milestone Courses

Nursing Division

GCSC offers multiple paths for students who are interested in the nursing profession. Students may progress through the workforce programs and, ultimately, complete the Baccalaureate Degree in Nursing (BSN) at GCSC.

The college also provides a transfer track for students who choose to complete the AA degree and transfer to a university to complete the BSN. The AA degree does not prepare students for licensure and does not include technical healthcare courses, it is specifically to prepare students to transfer to a university to complete a baccalaureate degree.

Certified Nursing Assistant – Career Certificate (CNA-VC)

AREA OF CONCENTRATION: This certificate program is designed to provide the education and skill level necessary to qualify for the state Certified Nursing Assistant exam. The two courses for this training are available at the Gulf/Franklin Campus in Port St. Joe, Florida. **This is a Limited Access Program.**

Professional Licensure Disclosure

Gulf Coast State College is approved to offer programs that may lead to professional licensure or certification in Florida. GCSC does not guarantee that programs which fulfill Florida licensing requirements will satisfy the criteria of professional licensure boards in other states, as each state has unique requirements for professional licensure or certification which are subject to change at any time and without notice.

Enrolled students and prospective students are strongly encouraged to contact their state's licensure entity to review all licensure or certification requirements imposed by their state(s) of choice. Please review the licensing board for guidance on the professional licensure or certification requirements for programs in your home state or where you would like to practice professionally.

GCSC is required by the National Council for State Authorization Reciprocity Agreements (NC-SARA) to disclose whether your prospective program meets the professional licensure or certification requirements in other states. NC-SARA does not address professional licensure issues.
<https://gulfcoast.edu/academics/online/professional-licensure-disclosure.html>

PLEASE NOTE: Gulf Coast State College is not requiring a COVID-19 vaccination. However, students completing clinical/practicum experiences in agencies and clinical sites that bill patients under Medicare and Medicaid must be fully vaccinated against COVID-19 or have received an exemption according to the CMS Interim Final Rule. Gulf Coast State College Nursing students will be asked to report vaccination

status (vaccinated or not vaccinated) to the program for clinical placement purposes. Exemptions to clinical site vaccination requirements will occur between the clinical site and the student because GCSC does not have a COVID-19 vaccination requirement.

The Certified Nursing Assistant program is a selective admission, limited enrollment program. Admission to Gulf Coast State College does not imply acceptance into the Certified Nursing Assistant program.

The Gulf/Franklin Campus offers a Hybrid CNA program with start dates each semester. This hybrid option will take approximately eight weeks to complete. Students are expected to attend two class sessions each week for lecture and laboratory/clinical skills.

The Certified Nursing Assistant student is prepared to give patient care under the supervision of a licensed nurse or physician. The student will be exposed to skills and have knowledge necessary to give safe and effective care to patients in a variety of settings.

Application Process:

- A. Apply to Gulf Coast State College
- B. Submit an application to the Certified Nursing Assistant program at the Gulf/Franklin Campus in Port St. Joe
- C. Submit official high school and any college or vocational transcripts to the Office of Enrollment Services
- D. Submit active scores on the TABE examination or equivalent PERT scores. TABE exams are given at the Gulf/Franklin Campus.

After meeting the above criteria, the applicant should contact the Gulf Franklin Campus to schedule an appointment with the Nursing Coordinator for advising and review of the application for completeness.

Applications must be completed and submitted by the last working day in June, October, or March for the next semester class. Due to the selection process, meeting minimum requirements does not guarantee admission.

After meeting the above criteria, the applicant should contact the Gulf/Franklin Campus to schedule an appointment with the Assistant Nursing Coordinator for advising and review of the application.

It is the responsibility of the student to maintain communication with the program advisor to ensure that the application is complete and up-to-date with current admission requirements.

Selection of students: During the first week after the application deadline, the selection committee will review all completed applications and make selections for the class.

Students are selected based on an admission criteria index. Those residing within the service district will be given preference in selection. Applicants will be notified by mail of selection status.

Requirements after Conditional Acceptance:

- Satisfactory fingerprint/background check
- Copy of current certification in Basic Life Support (BLS) from the American Heart Association
- Completion of physical examination (with satisfactory results), including immunization documentation

Applications are available from the Gulf/Franklin Campus, Port St. Joe, and from the Health Sciences Division, Panama City Campus.

Program Coordinator: Deborah Brzuska 850.913.3317

Curriculum Detail

Course Number	Course Name/Course Area	Credit Hours
HSC0003	Basic Healthcare Worker	90 ct/3v
HSC0725C	Nurse Aide & Orderly (Articulated)	75 ct/2.5v
TOTAL CERTIFICATE HOURS		165 ct/5.5v

After completion of the CNA program, students have the option to apply for the Practical Nursing program and will receive additional admission points for obtaining the CNA license.

Practical Nurse – Career Certificate (PHRS-VC)

AREA OF CONCENTRATION: The purpose of the Practical Nursing certificate program is to prepare students for eligibility to apply for the NCLEX-PN (National Council Licensure Examination for Practical Nurses) and obtain licensure in the State of Florida. This program is only available at the Gulf/Franklin Campus in Port St. Joe, Florida. **This is a Limited Access Program.**

Professional Licensure Disclosure

Gulf Coast State College is approved to offer programs that may lead to professional licensure or certification in Florida. GCSC does not guarantee that programs which fulfill Florida licensing requirements will satisfy the criteria of professional licensure boards in other states, as each state has unique requirements for professional licensure or certification which are subject to change at any time and without notice.

Enrolled students and prospective students are strongly encouraged to contact their state's licensure entity to review all licensure or certification requirements imposed by their state(s) of choice. Please review the licensing board for guidance on the professional licensure or certification

requirements for programs in your home state or where you would like to practice professionally.

GCSC is required by the National Council for State Authorization Reciprocity Agreements (NC-SARA) to disclose whether your prospective program meets the professional licensure or certification requirements in other states. NC-SARA does not address professional licensure issues.
<https://gulfcoast.edu/academics/online/professional-licensure-disclosure.html>

PLEASE NOTE: Gulf Coast State College is not requiring a COVID-19 vaccination. However, students completing clinical/practicum experiences in agencies and clinical sites that bill patients under Medicare and Medicaid must be fully vaccinated against COVID-19 or have received an exemption according to the CMS Interim Final Rule. Gulf Coast State College Nursing students will be asked to report vaccination status (vaccinated or not vaccinated) to the program for clinical placement purposes. Exemptions to clinical site vaccination requirements will occur between the clinical site and the student because GCSC does not have a COVID-19 vaccination requirement.

The program consists of 1,350 hours of study. The practical nursing student is prepared to give patient care under the supervision of a registered nurse or physician. The student will be exposed to skills and have knowledge necessary to give safe and effective care to patients in a variety of settings. The Practical Nursing program is a selective admission, limited enrollment program. Admission to Gulf Coast State College does not imply acceptance into the Practical Nursing program.

Application Process:

- A. General admission to the college must be granted prior to applying to the Practical Nurse program. General admission to Gulf Coast State College **does not** imply acceptance into the Practical Nurse program.
- B. Submit an application to the Practical Nursing program at the Gulf/Franklin Campus
- C. Submit official high school and any college or vocational transcripts to the Office of Enrollment Services
- D. Submit active, satisfactory scores on the TABE examination or equivalent PERT scores. TABE exams are given at the Gulf/Franklin Campus. Successful completion of the TABE is required for graduation.
- E. CNAs must submit a copy of certification to the Gulf/Franklin Campus Nursing Department

Applications must be completed and submitted by the last working day in June for the fall class. Due to the selection process, meeting minimum requirements does not automatically guarantee admission.

After meeting the above criteria, the applicant should contact the Gulf/Franklin Campus to schedule an appointment with the Nursing Coordinator for advising and review of application.

It is the responsibility of the student to maintain communication with the program advisor to ensure that the application folder is complete and up-to-date with current admission requirements.

Selection of Students: During the first week in May, the selection committee will review all completed applications and make selections for the class. Students are selected based on an admission criteria index. Those residing within the service district will be given preference in selection. Applicants will be notified by mail of selection status.

Requirements after Conditional Acceptance:

- Satisfactory fingerprint/background check
- Copy of current certification in Basic Life Support (BLS) from the American Heart Association
- Completion of physical examination (with satisfactory results), including immunization documentation

Applications are available from the Gulf/Franklin Campus, Port St. Joe, and from the Health Sciences Division, Panama City Campus.

Program Coordinator: Deborah Brzuska 850.913.3317

Curriculum Detail

Course Number	Course Name/Course Area	Credit Hours
PRN0098C	Practical Nursing Foundations I	300 ct/10.0v
PRN0099C	Practical Nursing Foundations II	300 ct/10.0v
PRN0290C	Medical Surgical Nursing I	300 ct/10.0v
PRN0690C	Comprehensive Nursing & Transitional Skills	150 ct/5.0v
TOTAL CERTIFICATE HOURS		1350 ct/45.0v

Nursing, Associate Degree (RN-AS)

LPN-to-ADN ARTICULATION

AREA OF CONCENTRATION: This program is designed to facilitate the transition from the role of Licensed Practical Nurse to Registered Nurse. LPN applicants may earn up to 17 credit hours of nursing based on competency testing results.

The Nursing program is a selective admission, limited enrollment program. Admission to Gulf Coast State College and the satisfaction of minimum requirements do not automatically guarantee admission.

Before beginning this program of study, students should obtain a program application packet from the Division of Nursing containing a *current* listing of admission requirements. **This is a Limited Access Program.**

Professional Licensure Disclosure

Gulf Coast State College is approved to offer programs that may lead to professional licensure or certification in Florida. GCSC does not guarantee that programs which fulfill Florida licensing requirements will satisfy the criteria of professional licensure boards in other states, as each state has unique requirements for professional licensure or certification which are subject to change at any time and without notice.

Enrolled students and prospective students are strongly encouraged to contact their state's licensure entity to review all licensure or certification requirements imposed by their state(s) of choice. Please review the licensing board for guidance on the professional licensure or certification requirements for programs in your home state or where you would like to practice professionally.

GCSC is required by the National Council for State Authorization Reciprocity Agreements (NC-SARA) to disclose whether your prospective program meets the professional licensure or certification requirements in other states. NC-SARA does not address professional licensure issues. <https://gulfoast.edu/academics/online/professional-licensure-disclosure.html>

PLEASE NOTE: Gulf Coast State College is not requiring a COVID-19 vaccination. However, students completing clinical/practicum experiences in agencies and clinical sites that bill patients under Medicare and Medicaid must be fully vaccinated against COVID-19 or have received an exemption according to the CMS Interim Final Rule. Gulf Coast State College Nursing students will be asked to report vaccination status (vaccinated or not vaccinated) to the program for clinical placement purposes. Exemptions to clinical site vaccination requirements will occur between the clinical site and the student because GCSC does not have a COVID-19 vaccination requirement.

Program Coordinator: Debbie Brzuska 850.913.3317

Application Process: Complete application process as noted in the LPN-to-AND program articulation application.

Minimum Requirements for Admission to LPN-to-ADN

Articulation: Prior to entering NUR1005C Nursing Transition, students must follow the checklist for students seeking LPN transition admission as outlined in the LPN-to-AND articulation packet.

Requirements for completion of additional cognate courses will be determined based on placement of applicant within the nursing sequence.

Students choosing Option A in the articulation packet are required to take Excelsior College Mobility Exams. Official results from the following mobility exams must be sent to the Office of Enrollment Services and a copy sent to the nursing department BEFORE the applicant can enroll in NUR1005C. Guidelines for awarding of credit once accepted into the program are as follows:

Excelsior College Mobility Exam and Number:

Fundamentals of Nursing (NURX-210)

GCSC Credit: NUR1022C

Maximum Required for Credit: Grade of "C"

Maximum Credit Hours: 3

Adult Nursing (NURX-310)

GCSC Credit: NUR1213C

Minimum Required for Credit: Grade of "C"

Maximum Credit Hours: 10

Foundations of Gerontology (SOCX-310)

GCSC Credit: NUR1210C

Minimum Required for Credit: Grade of "C"

Maximum Credit Hours: 4

Students choosing Option B in the articulation packet are required to enroll in NUR1000C (Nursing Transitions, 5 credit hours). Content of the previous Practical Nursing content areas of Foundations of Nursing Practice, Adult Nursing, and Foundations of Gerontology will be validated in this course.

Maximum Credit Hours: 5

- A. Official transcripts must be sent to Enrollment Services.
- B. A current copy of the applicant's nursing license must be on file in the Division of Nursing.
- C. Copy of valid CPR certification. The American Heart Association Health Care Provider Life Support Course is the only acceptable certification.
- D. Current Interprofessional Healthcare Training in: HIV/AIDS, Domestic Violence, Medical Errors, Infection Control, IV Therapy, and HIPAA.

Scheduling Options:

The *Traditional Scheduling Option* allows the student to merge into the third semester of an existing weekday RN class. Once selected, this option allows students to complete the RN program in two semesters. Students may be selected to enter the Traditional option during either fall or spring semesters.

The *Weekend Scheduling Option* selects two classes of students per year. Classes start every fall and spring semester and meet Friday afternoon with 12.5- hour Saturday or Sunday clinicals.

Additional Information:

- Retention and Dismissal Requirements** – Refer to the Nursing Student Handbook
- Readmission Requirements** – Refer to the Nursing Student Handbook
- Transfer Credits** – Refer to the AS degree nursing designated curriculum
- Graduation Requirements** – Refer to the AS degree nursing designated curriculum
- Course Curriculum** – Refer to the AS degree nursing designated curriculum

Upon conditional acceptance into the nursing program, students must also submit:

- A. Satisfactory fingerprint/criminal background check
- B. Medical examination with satisfactory results and copy of complete immunization record, including Hepatitis B immunization or signed waiver, and PPD or medical denial of symptoms
- C. Ten-panel drug screen with satisfactory results

Nursing, Associate Degree (RN-AS)

AREA OF CONCENTRATION: The purpose of the associate in science nursing program is to prepare students for eligibility to apply for the Registered Nurse National Council Licensing Examination (NCLEX).

The nursing program is fully approved by the Florida State Board of Nursing and accredited by the Accreditation Commission for Education in Nursing (ACEN) formerly the National League of Nursing and the Accrediting Commission (NLNAC). Institutional membership is maintained in the NLN Council of Associate Degree Programs and the National Organization of Associate Degree Nursing. **This is a Limited Access Program.**

Professional Licensure Disclosure

Gulf Coast State College is approved to offer programs that may lead to professional licensure or certification in Florida. GCSC does not guarantee that programs which fulfill Florida licensing requirements will satisfy the criteria of professional licensure boards in other states, as each state has unique requirements for professional licensure or certification which are subject to change at any time and without notice.

Enrolled students and prospective students are strongly encouraged to contact their state's licensure entity to review all licensure or certification requirements imposed by their state(s) of choice. Please review the licensing board for guidance on the professional licensure or certification requirements for programs in your home state or where you would like to practice professionally.

GCSC is required by the National Council for State Authorization Reciprocity Agreements (NC-SARA) to disclose whether your prospective program meets the professional licensure or certification requirements in other states. NC-SARA does not address professional licensure issues. <https://gulfcoast.edu/academics/online/professional-licensure-disclosure.html>

PLEASE NOTE: Gulf Coast State College is not requiring a COVID-19 vaccination. However, students completing clinical/practicum experiences in agencies and clinical sites that bill patients under Medicare and Medicaid must be fully vaccinated against COVID-19 or have received an exemption according to the CMS Interim Final Rule. Gulf Coast State College Nursing students will be asked to report vaccination status (vaccinated or not vaccinated) to the program for clinical placement purposes. Exemptions to clinical site vaccination requirements will occur between the clinical site and the student because GCSC does not have a COVID-19 vaccination requirement.

Upon successful completion of the prescribed course of study, students receive an Associate in Science Degree in Nursing which enables them to apply for the National Council Licensure Examination (NCLEX-RN). Upon successful completion of this examination, the Registered Nurse (RN) License is received.

This program will articulate into a baccalaureate degree program in nursing at all Florida universities in the State University System following graduation.

Before beginning this program of study, students should obtain a program application packet from the Division of Nursing containing a *current* listing of admission and course requirements.

Program Coordinator: Martha Ruder 850.913.3314

APPLICATION PROCESS:

The items below are listed only as a general guide. Students should obtain a current application packet for the complete listing of entry requirements.

1. Apply to Gulf Coast State College. General admission to the college must be granted prior to applying to the Nursing program. General admission to Gulf Coast State College **does not** imply acceptance into the Nursing program.
2. Submit the completed nursing program application to the Nursing Division by the published deadline
3. Submit all previous official school transcripts (including high school/GED and all previous colleges) to the Office of Enrollment Services for evaluation
4. Submit proof, as outlined in the application packet, of college-level competency in reading, English, and math
5. Successfully complete, with a "C" or higher, BSC2085 and BSC2085L (Anatomy & Physiology I lecture and lab)
6. Successfully complete, with a "C" or higher, a 3-credit hour college-level math course with a prefix of MAC, MGF, or STA
7. Successful completion, with a "C" or higher, POS2041, American National Government or AMH2020, US History II.
8. Contact Academic Program Specialist, Nursing, to be assigned a nursing faculty advisor
9. Successfully complete the Health Education Systems Incorporated (HESI) exam. Registration process, study information, and minimum scores required are contained in the nursing application packet.

The Nursing program is a selective admission, limited enrollment program. Admission to Gulf Coast State College and the satisfaction of minimum requirements does not automatically guarantee admission. When space is limited, preference may be given to students within the college's service district.

Deadline for Selection: All entry requirements, as outlined in the program application packet, must be completed by the appropriate deadlines for the two start dates each year. The deadline for the fall start date is the last working day of February and the deadline for the spring start date is the last working day of September.

Requirements for Conditional Acceptance:

- A. Satisfactory fingerprint/criminal background check
- B. Copy of valid CPR certification. The American Heart Association Health Care Provider Life Support Course is the only acceptable certification.
- C. Completion of physical examination (with satisfactory results), including copy of immunization form
- D. Ten-panel drug screen with satisfactory results

Refer to the Nursing Student Handbook for retention, dismissal, and readmission policies.

Transfer Credit: Academic courses taken at other colleges are transferable provided credit and laboratory hours correspond with those required at GCSC. CLEP credits are acceptable for transfer according to college policy. The possibility of transferring nursing courses can be determined only after a review of the individual's transcript and course outlines. Advanced placement students are admitted on a space-available basis.

DEP2004	Developmental Psychology	3
NUR1022C	Foundations of Nursing Practice	3
NUR1210C	Basic Care of the Adult	4
NUR1213C	Intermediate Adult Care	10
NUR1142	Introduction to Pharmacology	2
NUR2420C	Maternal-Infant Nursing	4
NUR2310C	Nursing Care of the Child	4
NUR2520C	Psychiatric-Mental Health Nursing	4
NUR2214C	Advanced Adult Care	11
TOTAL DEGREE HOURS		72

***Milestone Courses**

Curriculum Detail

Course Number	Course Name/Course Area	Credit Hours
Communications Area – 3 credit hours		
ENC1101 OR ENC1101C	English Composition I OR Enhanced English Composition	3
Humanities Area – 3 credit hours		
	Visual & Performing Arts OR Philosophy/Religion OR Literature	3
Mathematics Area – 3 credit hours		
	College-level mathematics	3
Natural Sciences Area – 8 credit hours		
BSC2085*	Anatomy & Physiology I	3
BSC2085L*	Anatomy & Physiology I Lab	1
BSC2086	Anatomy & Physiology II	3
BSC2086L	Anatomy & Physiology II Lab	1
Social Sciences Area – 3 credit hours		
POS2041 OR AMH2020	American National Government OR US History II	3
Major Courses – 52 credit hours		
MCB2004*	Microbiology	3
MCB2004L*	Microbiology Lab	1
HUN1201	Principles of Nutrition	3

Nursing Option, Liberal Arts AA (NUR-AA)

AREA OF CONCENTRATION: This curriculum is designed to prepare students for entry into a 4-year university bachelor's degree nursing (BSN) program. Students are strongly encouraged to be in close contact with the GCSC nursing program coordinator and a BSN advisor at the university they plan to attend before beginning this course of study. Students need a clear understanding of the university admission requirements and the difference between AA and AS nursing programs. Completing this AA option will not result in eligibility to sit for the licensing exam to become a registered nurse. Please refer to the AS degree option should that be your goal at GCSC.

Faculty Advisors: Assigned Nursing Faculty

Curriculum Detail

Course Number	Course Name/Course Area	Credit Hours
Communications Area – 6 credit hours		
ENC1101 OR ENC1101C	English Composition I OR Enhanced English Composition	3
ENC1102	English Composition II	3
Humanities Area – 9 credit hours		
	Visual and Performing Arts	3
	Philosophy/Religion	3
	Literature	3
Mathematics Area – 6 credit hours		
STA2023	Statistics	3
	College-level mathematics	3
Natural Sciences Area – 6 credit hours		
CHM1032*	General, Organic, Biochemistry or higher-level chemistry	3
BSC2085*	Anatomy & Physiology I	3
Social Sciences Area – 9 credit hours		
PSY2012 or SYG2000	General Psychology or Introduction to Sociology	3
	History	3
	Government	3
Transfer Common Prerequisites – 15 credit hours		
BSC2085L*	Anatomy & Physiology I Lab	1
BSC2086	Anatomy & Physiology II	3
BSC2086L	Anatomy & Physiology II Lab	1
HUN1201	Principles of Nutrition	3
MCB2004	Microbiology	3
MCB2004L	Microbiology Lab	1
DEP2004	Developmental Psychology	3
Electives – 9 credit hours		9
TOTAL DEGREE HOURS		60

*Milestone Courses

Nursing, Bachelor of Science in Nursing (RNB-BSN)

The Bachelor of Science in Nursing at GCSC is an RN to BSN completion program that builds from the Associate in Science in Nursing allowing a licensed RN to earn a Bachelor of Science degree with a major in nursing. (Students with a diploma in nursing will be evaluated individually after application to the college.) The competitive, limited program gives preference to Bay, Gulf, and Franklin County residents. **This is a Limited Access Program.**

Professional Licensure Disclosure

Gulf Coast State College is approved to offer programs that may lead to professional licensure or certification in Florida. GCSC does not guarantee that programs which fulfill Florida licensing requirements will satisfy the criteria of professional licensure boards in other states, as each state has unique requirements for professional licensure or certification which are subject to change at any time and without notice.

Enrolled students and prospective students are strongly encouraged to contact their state's licensure entity to review all licensure or certification requirements imposed by their state(s) of choice. Please review the licensing board for guidance on the professional licensure or certification requirements for programs in your home state or where you would like to practice professionally.

GCSC is required by the National Council for State Authorization Reciprocity Agreements (NC-SARA) to disclose whether your prospective program meets the professional licensure or certification requirements in other states. NC-SARA does not address professional licensure issues. <https://gulfoast.edu/academics/online/professional-licensure-disclosure.html>

PLEASE NOTE: Gulf Coast State College is not requiring a COVID-19 vaccination. However, students completing clinical/practicum experiences in agencies and clinical sites that bill patients under Medicare and Medicaid must be fully vaccinated against COVID-19 or have received an exemption according to the CMS Interim Final Rule. Gulf Coast State College Nursing students will be asked to report vaccination status (vaccinated or not vaccinated) to the program for clinical placement purposes. Exemptions to clinical site vaccination requirements will occur between the clinical site and the student because GCSC does not have a COVID-19 vaccination requirement.

The following degree plan is only appropriate for the student who is already a registered nurse. For initial entry into the GCSC nursing program, please see the requirements for Nursing, Associate degree.

PROGRAM GOAL: The Bachelor of Science in Nursing is designed to prepare licensed nurses for evidence-based practice and leadership in an ever-changing health care environment. BSN graduates will also have the opportunity to continue their education in a variety of specialty areas.

Division Chair: Keri Matheus 850.769.1551 x6695

Curriculum Detail

Course Number	Course Name/Course Area	Credit Hours
Communications Area – 6 credit hours		
ENC1101 OR ENC1101C	English Composition I OR Enhanced English Composition	3
ENC1102	English Composition II	3
Humanities Area – 9 credit hours		
	Visual & Performing Arts	3
	Philosophy/Religion	3
	Literature	3
Mathematics Area – 6 credit hours		
	College-level mathematics	3
STA2023*	Statistics	3
Natural Sciences Area – 6 credit hours		
BSC2085*	Human Anatomy & Physiology I	3
CHM1032*	General, Organic, Biochemistry or higher-level chemistry (CHM1040 or CHM1045)	3
Social Sciences Area – 9 credit hours		
	Behavioral Science	3
	History	3
	Government	3
Associate Degree/Diploma in Nursing – 48 credit hours		
NUR3069	Advanced Health Assessment	3
NUR3119	Nursing Concepts & Theories	3
NUR3128	Pathophysiology	3
NUR3167	Research Process for Professional Nursing	3
NUR3895	Teaching & Learning for the Healthcare Professional	3
NUR3636C	Community Health	4
NUR3925	Symposium I	1
NUR4655	Multicultural Factors in Health	3
NUR4827C	Leadership & Management	4
NUR4925	Symposium II	1
NUR4837	Healthcare Policy & Economics	3
NUR4847	Clinical Decision Making	3
NUR4945C	Nursing Capstone Practicum	2
TOTAL DEGREE HOURS		120

*Milestone Courses

Admission Requirements:

1. Completion of an associate degree program or diploma program in nursing from an accredited program and regionally accredited school or college
2. Documentation of current RN licensure with no restrictions
3. Completion of Application for General Admission to GCSC
4. Completion of Nursing Division Application for the RN to BSN program
5. Submission of all official transcripts by established deadline
6. Documentation of a Grade Point Average (GPA) of 2.50 or higher in all college credit courses and a "C" or higher in all prerequisite courses applicable to the RN to BSN program
7. Completion of the standard Florida foreign language upper division admission requirement. If, at the time of admission, the student has not completed two consecutive years of the same foreign language in high school or eight (8) credit hours in college, the student must complete eight (8) credit hours of foreign language before completing the program.
8. Completion of all required common prerequisites

The following is required after acceptance into the BSN program:

- Satisfactory fingerprint/criminal background check
- Copy of valid CPR certification
- Completion of physical examination (with satisfactory result), including copy of immunization form
- Satisfactory drug screening (may be required based upon the clinical agency requirements)
- Background check required. Admission will be contingent on a satisfactory fingerprint/criminal background check.
- Current PPD or TB test or declination with x-ray results

Registered Nurse First Assistant Advanced Technical Certificate (RNAF-ATC)

AREA OF CONCENTRATION: These courses are designed to introduce the certified perioperative nurse (CNOR), Eligible registered nurse, or advanced registered nurse practitioner (ARNP) to the perioperative specialty of surgical first assisting with a focus on the intraoperative component. Roles and responsibilities of the RNFA along with the principles and surgical techniques of first assisting practice are covered. The Competency Credentialing Institute, Association of Perioperative Nurses (AORN), and the Florida Nurse Practice Act. Upon completion of all core graduation requirements, graduates of this program will receive a Registered Nurse First Assistant Advanced Technical Certificate (RNAF-ATC). Successful completion of the program will allow graduates to apply to take the national certifying examination "Certified

Registered Nurse First Assistant (CRNFA)" offered through the Competency Credentialing Institute (CCI) provided all the eligibility requirements currently established are met. Course completion is achieved within one year for all courses. The combination lab/clinical course provides "hands on" experience in the registered nurse first assistant role. Students complete an on-site lab experience. Exact dates are available from the Coordinator of Surgical Services. To apply for this program of study, students should obtain a program application packet from the Division of Health Sciences containing a current listing of admission and course requirements. **This is a Limited Access Program.**

Professional Licensure Disclosure

Gulf Coast State College is approved to offer programs that may lead to professional licensure or certification in Florida. GCSC does not guarantee that programs which fulfill Florida licensing requirements will satisfy the criteria of professional licensure boards in other states, as each state has unique requirements for professional licensure or certification which are subject to change at any time and without notice.

Enrolled students and prospective students are strongly encouraged to contact their state's licensure entity to review all licensure or certification requirements imposed by their state(s) of choice. Please review the licensing board for guidance on the professional licensure or certification requirements for programs in your home state or where you would like to practice professionally.

GCSC is required by the National Council for State Authorization Reciprocity Agreements (NC-SARA) to disclose whether your prospective program meets the professional licensure or certification requirements in other states. NC-SARA does not address professional licensure issues. <https://gulfoast.edu/academics/online/professional-licensure-disclosure.html>

PLEASE NOTE: Gulf Coast State College is not requiring a COVID-19 vaccination. However, students completing clinical/practicum experiences in agencies and clinical sites that bill patients under Medicare and Medicaid must be fully vaccinated against COVID-19 or have received an exemption according to the CMS Interim Final Rule. Gulf Coast State College Nursing students will be asked to report vaccination status (vaccinated or not vaccinated) to the program for clinical placement purposes. Exemptions to clinical site vaccination requirements will occur between the clinical site and the student because GCSC does not have a COVID-19 vaccination requirement.

Program Coordinator: Shannon Smith 850.769.1551

Curriculum Detail

Course Number	Course Name/Course Area	Credit Hours
NSP2290	Perioperative Nursing Theory	3
NSP2090	Registered Nurse First Assistant Theory	3
NSP2090L	Registered Nurse First Assistant Theory Lab and Clinical	3
TOTAL CERTIFICATE HOURS		9

APPLICATION PROCESS:

- A. Apply to Gulf Coast State College. General admission to the college must be granted prior to applying to the Registered Nurse First Assistant program. General admission to Gulf Coast State College **does not** imply acceptance into the Registered Nurse First Assistant program.
- B. Submit the Registered Nurse First Assistant program application forms, a copy of your current licensure as an RN or ARNP, if RN, submit a copy of CNOR or CNOR eligibility
- C. Submit the Verification of Eligibility form for the program
- D. Submit official high school or GED transcripts to the Office of Enrollment Services
- E. Submit official transcripts from all previous colleges to the Office of Enrollment Services for evaluation
- F. Have two letters of reference mailed to the program coordinator
- G. Complete the clinical requirements as articulated by the clinical facility for the clinical internship

Recommended Degree Plan: Please refer to the degree plan to determine what classes are typically offered each term. This represents a student's plan of approximately three semesters or one year for an Advanced Technical Certificate (ATC).

Summer:

NSP2290, Perioperative Nursing Theory or proof of CNOR status as eligible with date to sit for examination (required prior to program completion)

NSP2090, Registered First Assistant Theory

Fall:

NSP2090L, Registered Nurse First Assistant Lab and Clinical

PERIOPERATIVE NURSING

AREA OF CONCENTRATION: This course is designed to introduce the nursing student or registered nurse to Perioperative Nursing with a focus on the Intraoperative component. This course includes an introduction to the patient's perioperative experience, roles and responsibilities of the registered nurse; principles and practice of sterile

technique; sterilization and disinfection; operating room hazards; and an introduction to surgical technique.

Course completion must be achieved within one semester. A second course is available through cooperative education for "hands on" experience in the operating room – NSP2290. This course is offered in cooperation with clinical affiliates. NSP2290 offers advanced training in the area of surgical nursing for a second through fourth term current nursing student or as an open enrollment class to any licensed registered nurse. This course is a requirement for local hospitals for employment in the surgical area.

Curriculum Detail

Course Number	Course Name/Course Area	Credit Hours
NSP2290	Perioperative Nursing Theory	3
NSP2290L	Perioperative Nursing Lab	3
TOTAL CERTIFICATE HOURS		6

APPENDIX

- 1. ACADEMIC ADVISING SYLLABUS**
- 2. DEGREE PLANS**
- 3. PLACEMENT TEST SCORES**
- 4. MATHEMATICS & ENGLISH FLOW CHARTS**
- 5. COLLEGE CALENDAR**
- 6. RESOLUTION OF STUDENT ISSUES**
- 7. NOTES PAGE**

Academic Advising Syllabus

This academic advising syllabus is designed to enhance your advising experience at Gulf Coast State College. It is a resource to help you stay on track academically, and it provides a clear understanding of your responsibilities as a student as well as those of your academic advisor. Refer to this syllabus regularly and use it as a guide during your educational journey.



Academic Advising Mission

The mission of the academic advising program is to help students attain the academic credentials and professional skills necessary for their success.

Advising is a partnership in which students are guided in developing their interests and creating an efficient plan to achieve their goals.

Pathway To Success



Student Learning Outcomes

As a result of your active engagement in the advising process at Gulf Coast State College you will be able to:

- Recognize College requirements, deadlines, policies, and procedures.
- Make effective decisions concerning your degree and career goals.
- Develop an educational plan for successfully achieving your goals.
- Select courses each semester to progress toward fulfilling your educational plan.
- Utilize available campus resources and services to assist you in achieving your academic, personal, and career goals.
- Graduate in a timely manner based on your individual educational plan.
- Complete a degree audit by the time you are half-way through your program.

Advisee Responsibilities

- Take responsibility for educational experience
- Learn how to access and use GCSC email, Canvas, My Student Dashboard, and any other online student success platform
- Become familiar with and use campus resources
- Read and respond to college emails on a regular basis
- Know important dates and deadlines (registration, drop/add, fees due, withdrawal, financial aid, scholarships, final exams, graduation, etc.)
- Attend advising sessions prepared to ask questions and discuss concerns
- Maintain regular contact with assigned advisor throughout the semester
- Keep a copy of this advising syllabus

Advisor Responsibilities

- Be available to advisees through established means of communication
- Respond to advisee's emails in a timely manner
- Provide guidance and support with selecting a major, career exploration, and transfer planning
- Provide accurate information about program requirements, college resources, and services
- Provide assistance in developing and reviewing individual academic plans
- Assist students in selecting courses based on intended major, academic interest, career goals, etc.
- Monitor academic progress and assist with developing action plans for students who encounter academic difficulty
- Maintain confidentiality



Important Phone Numbers

Career/Academic Coach.....	850.769.1551 x2829
Counseling.....	850.759.1551 x4861
Enrollment Services.....	850.872.3839
Financial Aid	850.872.3845
IT Help Desk	850.913.3303
Library.....	850.872.3893
Student Accessibility Resources	850.747.3243
Testing Center	850.769.1551 x3594

Student Success Checklist

- Schedule an introductory meeting with your academic advisor.
- Set academic goals with your academic advisor.
- Develop an academic plan with your academic advisor.
- Schedule meetings with your academic advisor throughout the semester to make sure you are making progress toward achieving your academic goals and to plan for the next semester.
- Know your professors' contact information including office hours and email.
- Always attend class. If you are going to miss class, let your professors know immediately. If you miss a class, make sure you speak with your professors to discuss what you missed.
- Know resources available for extra assistance outside of class time:
 - Academic/Career Coach
 - Counseling
 - Library
 - ACE Lab
 - Math Lab
 - Reading and Writing Lab
 - Science Lab
 - Student Accessibility Resources
 - TRIO
- Know important dates: tests, assignments due, registration, etc.
- Understand the transition from high school to college is an on-going process that requires active engagement on your part.
- Begin to understand your unique learning style.
- Be organized and understand the importance of time management.
- Attend programs and activities that will help you to expand your knowledge of your own culture as well as others.
- Explore co-curricular and extra-curricular activities including student clubs and organizations, intramural sports, Honors Program, etc.
- If you are planning to transfer to a 4-year college or university, research and know the requirements for admission and graduation at that college or university.
- Know how to complete a degree audit by the time you are half-way through your program.

Important Dates for Fall 2023

Registration Begins.....	Monday, April 3, 2023
Fees Due.....	Friday, August 11, 2023
Classes Begin.....	Monday, August 21, 2023
Late Registration; Drop/Add.....	Monday, August 21 - Friday, August 25
Last Day to Apply for Fall Graduation.....	Monday, October 2, 2023
Last Day for Student to Initiate a Withdrawal.....	Friday, October 20, 2023
Final Examinations.....	Friday, December 8 - Thursday, December 14

Important Dates for Spring 2024

Registration Begins.....	Monday, November 6, 2023
Fees Due.....	Thursday, January 4, 2024
Classes Begin.....	Friday, January 5, 2024
Late Registration; Drop/Add.....	Friday, January 5 - Thursday, January 11
Last Day to Apply for Spring Graduation.....	Monday, February 19, 2024
Last Day for Student to Initiate a Withdrawal.....	Wednesday, March 6, 2024
Final Examinations.....	Friday, April 26 - Thursday, May 2

Important Dates for Summer 2024

Registration Begins.....	Monday, April 1, 2024
Fees Due.....	Tuesday, May 7, 2024
Classes Begin.....	Wednesday, May 8, 2024
Late Registration; Drop/Add.....	Wednesday, May 8 - Thursday, May 9
Last Day to Apply for Summer Graduation.....	Monday, June 3, 2024
Last Day for Student to Initiate a Withdrawal.....	Wednesday, June 26, 2024
Final Examinations.....	Wednesday, July 31 - Thursday, August 1

AA - GCSC DEGREE PLAN

Student Name: ID#:	Faculty Advisor:	Pathway Navigator:	Major:
-----------------------	------------------	--------------------	--------

Semester 1		Semester 2		Semester 3		Semester 4		Semester 5		Semester 6	
First Semester Courses	Second Semester Courses	Third Semester Courses	Fourth Semester Courses	Fifth Semester Courses	Sixth Semester Courses						
Total Hours	Total Hours	Total Hours	Total Hours	Total Hours	Total Hours	Total Hours		Total Hours		Total Hours	
* Requires C or better	* Requires C or better	* Requires C or better	* Requires C or better	* Requires C or better	* Requires C or better	* Requires C or better		* Requires C or better		* Requires C or better	

<input type="checkbox"/> Foreign Language Requirement AA or Baccalaureate Degree	<input type="checkbox"/> Civic Literacy Requirement (course and exam)	<input type="checkbox"/> Flexible Placement
---	--	---

Milestones	Milestones	Milestones	Milestones
Complete Career Coach Assessment	Narrow University Transfer Choices	Apply to the University	Apply for GCSC Graduation

External Credit: AP, IB, AICE, CLEP, DSST or Other Equivalent	Notes:

AS - GCSC DEGREE PLAN

Student Name:	Faculty Advisor:	Pathway Navigator:	Major:
ID#:			

	Semester 1	Semester 2	Semester 3	Semester 4	Semester 5	Semester 6
First Semester Courses	Second Semester Courses	Third Semester Courses	Fourth Semester Courses	Fifth Semester Courses	Sixth Semester Courses	
Total Hours	Total Hours	Total Hours	Total Hours	Total Hours	Total Hours	Total Hours
* Requires C or better	* Requires C or better	* Requires C or better	* Requires C or better	* Requires C or better	* Requires C or better	* Requires C or better

Civic Literacy Requirement (course and exam)

Flexible Placement

Milestones	Milestones	Milestones
Complete Career Coach Assessment	Develop Resume Draft	Complete Resume and Cover Letter
		Apply for GCSC Graduation

External Credit: AP, IB, AICE, CLEP, DSST or Other Equivalent	Notes:

AA - GCSC DEGREE PLAN

Student Name:	Faculty Advisor:	Pathway Navigator:	Major:
ID#:			

First Semester Courses	Second Semester Courses	Third Semester Courses	Fourth Semester Courses	Fifth Semester Courses	Sixth Semester Courses	Seventh Semester Courses	Eighth Semester Courses
Total Hours	Total Hours	Total Hours	Total Hours	Total Hours	Total Hours	Total Hours	Total Hours
* Requires C or better	* Requires C or better	* Requires C or better	* Requires C or better	* Requires C or better	* Requires C or better	* Requires C or better	* Requires C or better

<input type="checkbox"/> Foreign Language Requirement AA or Baccalaureate Degree	<input type="checkbox"/> Civic Literacy Requirement (course and exam)	<input type="checkbox"/> Flexible Placement
---	---	---

Milestones	Milestones	Milestones	Milestones
Complete Career Coach Assessment	Narrow University Transfer Choices	Apply to the University	Apply for GCSC Graduation

External Credit: AP, IB, AICE, CLEP, DSST or Other Equivalent	Notes:

AS-GCSC DEGREE PLAN

Student Name and ID:		Faculty Advisor:			Pathway Navigator:			Major:	
First Semester Courses	Second Semester Courses	Third Semester Courses	Fourth Semester Courses	Fifth Semester Courses	Sixth Semester Courses	Seventh Semester Courses	Eighth Semester Courses		
Total Hours	Total Hours	Total Hours	Total Hours	Total Hours	Total Hours	Total Hours	Total Hours		
<small>*Requires C or better</small>	<small>*Requires C or better</small>	<small>*Requires C or better</small>	<small>*Requires C or better</small>	<small>*Requires C or better</small>	<small>*Requires C or better</small>	<small>*Requires C or better</small>	<small>*Requires C or better</small>		

Civic Literacy Requirement (course and exam)

Flexible Placement

Milestones	Milestones
Complete Career Coach Assessment	Develop Resume Draft
	Complete Resume and Cover Letter
	Apply for GCSC Graduation

External Credit: AP, IB, AICE, CLEP, DSST or Other Equivalent	Notes:

ASSOCIATE IN ARTS (AA) DEGREE

Student's Name:	Student's ID Number:
Date:	Pathway Navigator/Faculty Advisor:
Transfer Track:	Intended Bachelor's Program:

General Education (36 Hours)

Transfer track programs often require that you take specific general education courses in each general education area. Below are the general education requirements for your program. Consult with your Faculty Advisor if you have any questions.

Communications (6 credits)

- ENC1101 English Composition I●+* 3
- ENC1101C Enhanced English Comp. I●+* 4
- ENC1102 English Composition II+* 3
- _____ 3

Humanities (9 credits)

One course each from Visual & Performing Arts, Philosophy/Religion, and Literature. At least one course must be a core course (●).

Humanities 1–Visual & Performing Arts

- ARH2000 Understanding Visual Arts● 3
- ARH2050 Art History I 3
- ARH2051 Art History II 3
- ARH2060 History of Architecture 3
- MUL2010 Understanding Music● 3
- MUL2110 Survey of Music Literature 3
- THE2000 Understanding Theater● 3
- THE2071 Survey of Film 3
- _____ 3

Humanities 2–Philosophy/Religion

Prerequisite ENC1101 or ENC1101C with grade "C" or higher.

- PHH2060 Intro. to Classical Philosophy+* 3
- PHI2002 Intro. to Modern Philosophy+* 3
- PHI2010 Intro. to Philosophy●+* 3
- PHI2600 Ethics+* 3
- PHI 2620 Environmental Ethics+* 3
- PHI2635 Biomedical Ethics+* 3
- REL2121 Intro. to Religion in America+* 3
- REL2300 Religions of the World+* 3
- REL2315 Eastern Religions+* 3
- SPN2200 Second Year–Spanish I+* 4
- _____ 4

Humanities 3–Literature

Prerequisite ENC1102 with grade "C" or higher.

- AML2010 Amer. Lit. through the Civil War+* 3
- AML2020 Amer. Lit: Reconstr.–Present+* 3
- AML2600 African-American Literature+* 3
- ENG2111 Literature and Film+* 3
- ENL2012 Eng. Lit. through the 18th Century+*3
- ENL2022 Eng. Lit.: Romantics to Present+* 3
- LIT2000 Literature and Culture●+* 3
- LIT2040 World Drama+* 3
- LIT2090 Contemporary Literature+* 3
- LIT2110 World Lit.: Ancient–Renaissance+* 3
- LIT2120 World Lit.: Enlightenment–Present+*3
- LIT2380 Women in Literature+* 3
- _____ 3

Mathematics (6 credits)

Two courses from Mathematics. At least one course must be a core course (●). The combination of STA2023 and STA2122 will not meet the math requirement. Successfully completing a math course for which a core course option in math is an immediate prerequisite will meet the math core requirement.

- MGF1106 Math for Liberal Arts●+* 3
- MGF1107 Survey of Mathematics●+* 3
- STA2023 Statistics●+* 3
- STA2122 Statistical Applications+* 4
- MAC1105 College Algebra●+* 3
- MAC1114 Plane Trigonometry+* 3
- MAC1140 Pre-Calculus Algebra+* 3
- MAC2233 Business Calculus+* 3
- MAC2311 Calculus with Geometry I●+* 4
- MAC2312 Calculus with Geometry II+* 4
- MAC2313 Calculus with Geometry III+* 4
- MAP2302 Differential Equations+* 3
- _____ 3

Natural Sciences (6 credits)

One course each from Physical Sciences and Biological Sciences. At least one course must be a core course (●).

Physical Sciences

- AST1002 Descriptive Astronomy● 3
- CHM1032 General, Organic, Biochemistry+ 3
- CHM1040 Fundamentals of Chemistry+ 3
- CHM1045 General Chemistry●+ 3
- ESC2000 Earth & Space Science Survey● 3
- EVR1001 Intro. to Environmental Science● 3
- GLY1010 Physical Geology 3
- GLY1032 Natural Disasters 3
- OCE1001 Fundamentals of Oceanography 3
- PHY1020 Basic Concepts of Physics● 3
- PHY1023 Survey of General Physics+ 3
- PHY2048 University Physics I●+ 4
- PHY2053 College Physics I●+ 3
- _____ 3

Biological Sciences

- BOT2800 Plants & Society 3
- BSC1005 General Biological Science● 3
- BSC1020 Human Biology 3
- BSC2010 Biology for Science Majors I●+ 3
- BSC2085 Anatomy & Physiology I●+ 3
- BSC2311 Introduction to Marine Biology 3
- _____ 3

Social Sciences (9 credits)

One course each from Behavioral Sciences, History, and Government. At least one course must be a core course (●). History & Government: Students are expected to take one Global course and one U.S. course. See Civic Literacy requirement under Other AA Requirements.

Behavioral Sciences

- ANT2000 Introduction to Anthropology● 3
- ECO2013 Principles of Economics, Macro● 3
- PSY2012 General Psychology● 3
- SYG2000 Principles of Sociology● 3
- _____ 3

History

- Global
- EUH1000 Western Civilization I 3
- EUH1001 Western Civilization II 3
- WOH 2012 World History I 3
- WOH 2022 World History II 3
- _____ 3

U.S.

- AMH2010 United States History I 3
- AMH2020 United States History II●@ 3
- _____ 3

Government

- Global
- CPO2002 Comparative Government 3
- U.S.
- POS2041 American Nat'l Government●@ 3
- POS2112 State & Local Government 3
- _____ 3

Developmental Courses

- ENC0022 Dev. Writing I & II Combined* 3
- REA0019 Dev. Reading I & II Combined* 3
- MAT0012 Dev. Arithmetic with Algebra* 3
- MAT0055 Dev. Mathematics Module I* 1
- MAT0056 Dev. Mathematics Module II* 2

Electives (24 Hours)

The 24 credit hours of electives that you must complete for the AA are determined by your transfer track program. See the catalog description of your transfer track program or your Pathway Navigator/Faculty Advisor for information about your program's specific elective requirements.

Course	Hours

Notes

Other AA Requirements

- General Education Core Requirement**
Successful completion of at least one dotted core course from each of the five major general education areas: Communications, Humanities, Mathematics, Natural Sciences, Social Sciences
- Civic Literacy Requirement (@)**
Successful completion of AMH 2020 OR POS 2041 AND passing score on civic literacy exam
- Foreign Language Requirement**
Successful completion of 2 years of high-school-level foreign language or 2 semesters of college-level foreign language

Key

- = General Education Core course
- + = Prerequisite or co-requisite required
- * = Minimum grade of "C" required
- @ = Course meets Civic Literacy Requirement



Test Score Worksheet for Placement (valid for two years from testing date)

Subtest	PERT	ACT	SAT	Course Placement
Writing & Reading	103-150 (W) 106-150 (R)	17 (E) & 19 (R)	24	ENC 1101 – English Composition I
Writing & Reading	86-102 (W) 86-105 (R)	15 (E) & 17 (R)	22	ENC 1101C – Enhanced English Composition I
Writing	50-85	Must take PERT to determine placement	Must take PERT to determine placement	ENC 0022 – Developmental Writing I & II
Reading	50-85	Must take PERT to determine placement	Must take PERT to determine placement	REA 0019 – Developmental Reading I & II
Subtest	PERT	ACT	SAT	Course Placement
Math	138-150 & 250-275 (AAF)*	23-27	25.50	MAC 1114 – Plane Trigonometry MAC 1140 – Pre-calculus Algebra MAC 2233 – Calculus for Business & Social Science
Math	123-150	20-22	24.50	MAC 1105 – College Algebra STA 2122 – Applied Statistics in Social Science
Math	114-122	19	24.00	STA 2023 – Statistics MGF 1106 – Mathematics for Liberal Arts MGF 1107 – Survey of Mathematics **MAT 1033 – Intermediate Algebra
Math	50-113	Must take PERT to determine placement	Must take PERT to determine placement	MAT 0012 – Developmental Arithmetic with Algebra

** = MAT 1033 does not meet General Education requirements

* = Advanced Algebra of Functions (Accuplacer Next Generation) effective as of 05/01/2020

Health Sciences Mathematics Flowchart

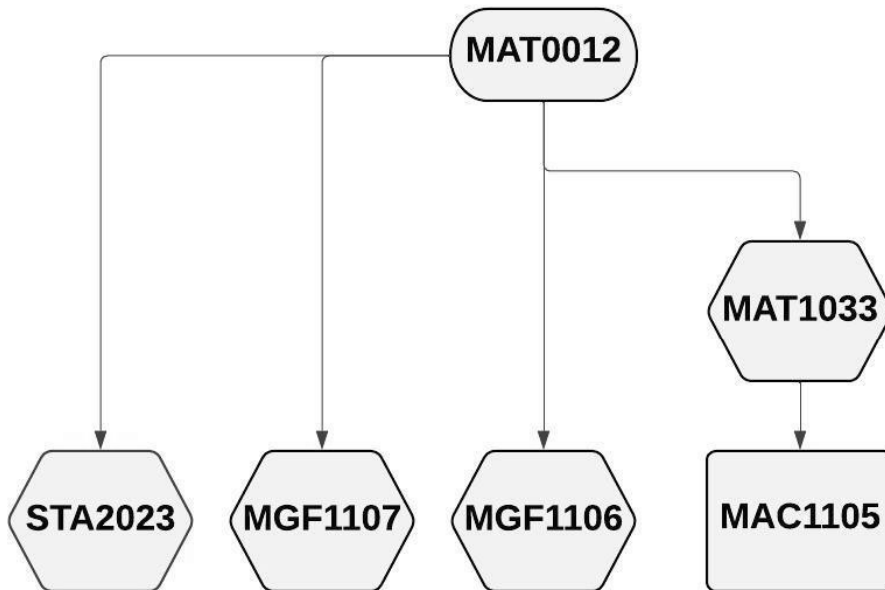

- MAT0012 is a developmental math courses designed for students with specific placement scores
- MAT1033 is a college-level credit course that does NOT count at college-level math
- Flexible placement allows a student to begin at MAT1033, MGF1106, MGF1107 or STA2023 without requiring a placmenet test; however, ONLY MAT1033 can be used as a prerequisite for MAC1105
- Courses that count as college-level math begin at MAC1105, MGF1106, MGF1107, STA2023
- Placement test scores (PERT, ACT, SAT) can be used to place students in higher level math courses
- Students must earn a grade of C or higher to pass and progress to the next level math course

Health Sciences Biology Flowchart

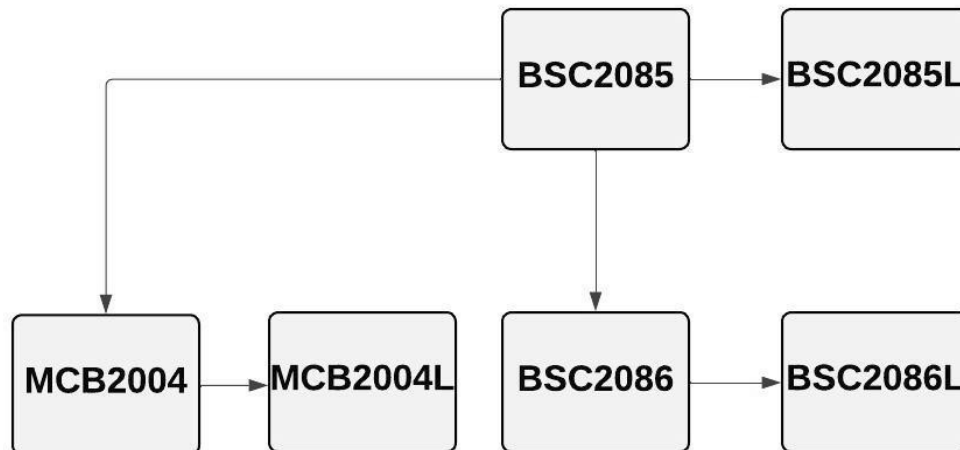

- All Biological Science courses required for Health Science majors require the associated laboratory course as a corequisite.
- Microbiology (MCG2004) requires a prerequisite of a biology course or chemistry course.

Chemistry Flowchart

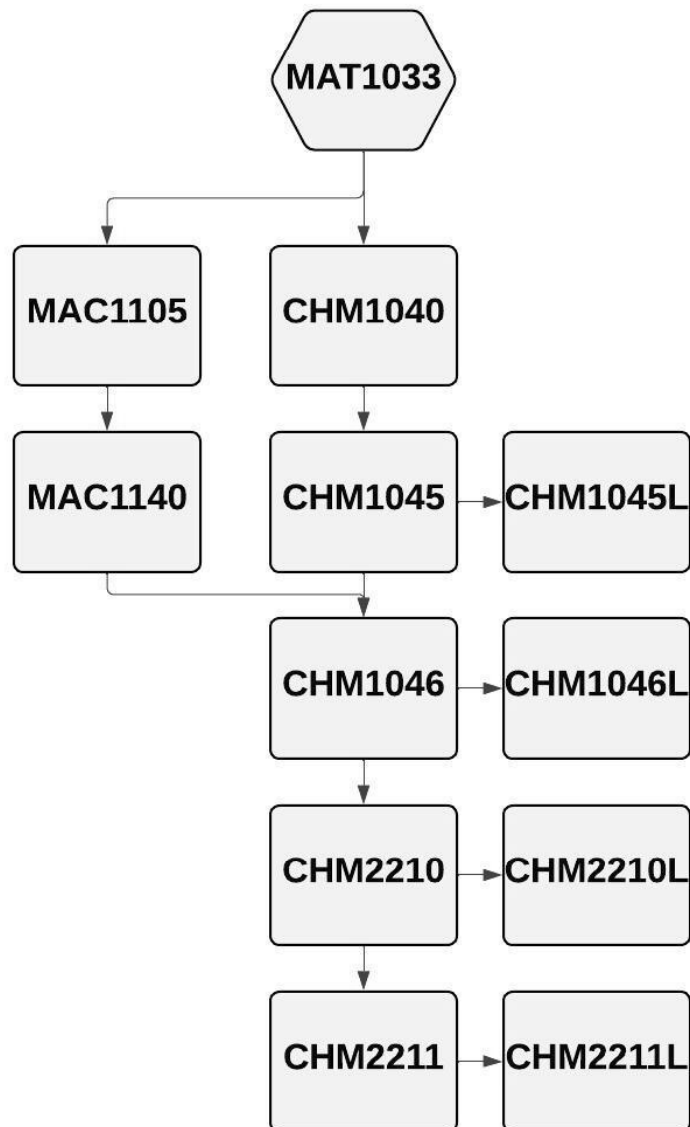

- General Chemistry I (CHM1045) and above require a corequisite of the associated laboratory course.
- General Chemistry I (CHM1045) requires the mathematics prerequisite of MAC1105.
- General Chemistry with Qualitative Analysis (CHM1046) requires the mathematics prerequisite of MAC1140.

English and Humanities Flowchart

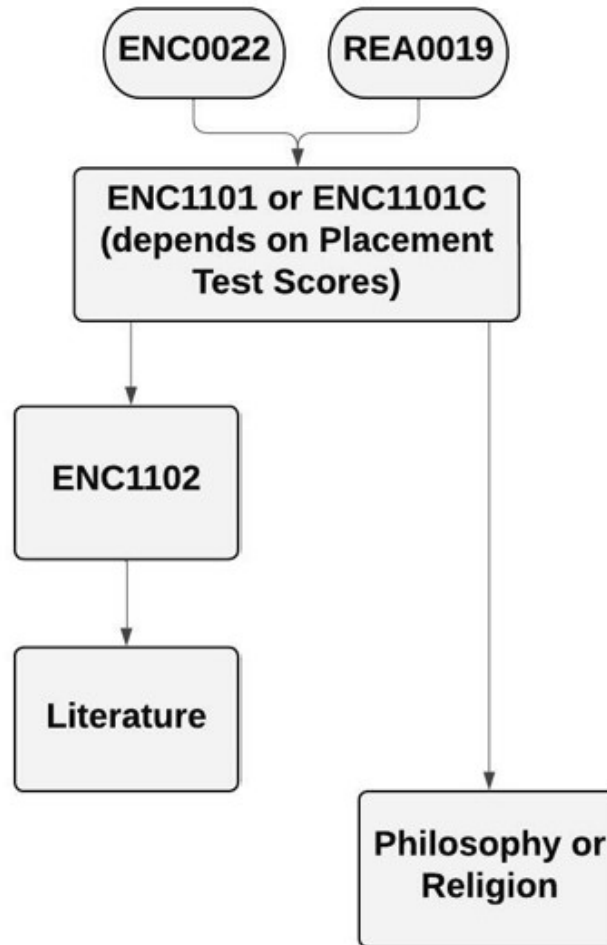

- ENC0022 and REA0019 are developmental courses, not college-level courses
- Students must earn a grade of C or higher to pass and progress to the next level course
- We recommend that students take literature before philosophy or religion
- Philosophy or religion courses might use APA, Chicago, Turabian, or another writing style that is appropriate for the discipline
- ENC1101, ENC1101C, ENC1102, and all literature use MLA

		Fall 2023 (202308)			Spring 2024 (202401)			Summer 2024 (202405)		
2023 - 2024 College Calendar		Session A 8/21 - 12/15	Session B 8/21 - 10/13	Session C 10/16 - 12/15	Session A 1/5 - 5/3	Session B 1/5 - 2/28	Session C 2/29 - 5/3	Session A 5/8 - 8/2	Session B 5/8 - 6/19	Session C 6/20 - 8/2
First time in college students must attend an orientation session to be eligible for registration.										
Early Registration for Students Receiving Veteran Benefits from GSCC	March 31	March 31	March 31	March 31	November 3	November 3	November 3	March 29	March 29	March 29
Open Registration for all campuses (excludes Sat., Sun., & holidays) See in - service Day below.*	April 3	April 3	April 3	April 3	November 6	November 6	November 6	April 1	April 1	April 1
Web registration will be available when college is closed except for scheduled maintenance windows.										
Registration Fees Due	August 11	August 11	(After August 11, fees due at point of registration)	January 4	January 4	(After January 4, fees due at point of registration)	May 7	May 7	(After May 7, fees due at point of registration)	June 20
Classes Begin	August 21	August 21	October 16	January 5	January 5	February 29	May 8	May 8	June 20	June 20
State Employee Fee Waiver Registration	August 21 - 25	August 21 - 25	October 16 - 17	January 5 - 11	January 5 - 11	February 29 - March 4	May 8 - 9	May 8 - 9	June 20 - 24	June 20 - 24
Drop/Add	August 21 - 25	August 21 - 25	October 16 - 17	January 5 - 11	January 5 - 11	February 29 - March 4	May 8 - 9	May 8 - 9	June 20 - 24	June 20 - 24
Last day to submit residency fee waiver documentation (by 4:00 p.m.)	August 25	August 25	October 17	January 11	January 11	March 4	May 9	May 9	June 24	June 24
Last day to cancel registration/drop courses and receive a refund (by 11:59 p.m.)	August 25	August 25	October 17	January 11	January 11	March 4	May 9	May 9	June 24	June 24
Last day to change major and credit to audit	August 25	August 25	October 17	January 11	January 11	March 4	May 9	May 9	June 24	June 24
Midterm	October 13	September 18	November 13	February 28	February 1	April 2	June 19	May 29	July 11	July 11
Student Informed Withdrawal deadline	October 20	September 25	November 20	March 6	February 8	April 9	June 26	June 5	July 18	July 18
Final Examinations	December 8 - 14	October 11 - 13	December 11 - 14	April 26 - May 2	February 27 - February 28	April 29 - May 2	July 31 - August 1	June 18 - 19	August 2	August 2
Term Ends	December 15	October 13	December 15	May 3	February 28	May 3	August 2	June 19	August 2	August 2
Grades available via Banner	December 19	October 17	December 19	May 7	March 4	May 7	August 6	June 21	August 6	August 6
Graduation Application deadline	October 2	October 2	October 2	February 19	February 19	February 19	June 3	June 3	June 3	June 3
In order for summer graduates to participate in the spring ceremony, they must submit their summer graduation application prior to the spring application deadline. No exceptions.										
Honors Convocation				April 26						
Commencement				May 3						
College Closed for all students										
*In-service Day	August 16									
Student Holidays - Classes will not be held on these days	September 2 - 4			January 2 - 4			May 25 - 27			
	November 10 - 12			January 13 - 15			July 4			
	November 22 - 26			March 16 - 22						
Faculty - Christmas Break / New Year	December 15 - January 1									
Faculty - Christmas Break / New Year	December 18 - January 1									
College closed for all students and employees										
Memorial Day							May 25 - 27			
Independence Day							July 4			
Labor Day	September 2 - 4									
Veteran's Day	November 10 - 12									
Thanksgiving Holidays	November 23 - 26									
Christmas Break / New Year's Holiday	December 22 - January 1									
Martin Luther King, Jr. Day				January 13 - 15						
Spring Break				March 16 - 22						

Gulf Coast State College reserves the right to change the college calendar, or to make other changes deemed necessary, giving advance notice of change when possible.

ISSUE	FIRST RESPONSE	NEXT LEVEL	NEXT LEVEL 2	FINAL ADMINISTRATIVE LEVEL
Academic Stranding	Navigation Center	Counselor		Dean of Student Engagement
First Term Academic Advising	Navigation Center			Dean of Student Engagement
Program Academic Advising	Faculty Academic Advisor	Academic Division Chair	Navigation Center	Dean of Student Engagement
Canvas, GCSC Email, Lighthouse Issue	ITS Website	Technical Support		Chief Information Officer
Admission Application	Application Process Specialist	Coordinator of Enrollment Services	Executive Director of Enrollment Services	Dean of Student Engagement
Bookstore	Bookstore Cashier	Coordinator of Bookstore	Executive Director of Procurement and Auxiliary Services	Dean of Business Affairs
Contact Instructor	Course Syllabus	GCSC Website, Employee Directory	Academic Division Chair	Vice President of Academic Affairs
Course Refund Requests				Dean of Student Engagement
Discrimination	GCSC Employee	Dean of Student Life		Executive Director of Human Resources
Evening Campus Contact	College Employee	Campus Custodial Staff		Executive Director of Operations
Faculty Concerns	Faculty Member	Academic Division Chair		Vice President of Academic Affairs
Financial Aid	Financial Aid Staff	Director of Financial Aid	Executive Director of Student Financial Services	Dean of Business Affairs
GCSC Foundation Scholarship	Foundation Staff	Finance and Scholarship Program Manager	Executive Director of GCSC Foundation	College President
Graduation	Graduation Specialist	Coordinator of Enrollment Services	Executive Director of Enrollment Services	Dean of Student Engagement
Harassment	GCSC Employee	Dean of Student Life		Executive Director of Human Resources
Library	Library Professional Staff	Director of the Library		Vice President of Academic Affairs
Orientation	Director of Navigation Center			Dean of Student Engagement
Password Reset	ITS Website	ITS Help Desk		Chief Information Officer

ISSUE	FIRST RESPONSE	NEXT LEVEL	NEXT LEVEL2	FINAL ADMINISTRATIVE LEVEL
Registration	Enrollment Specialist	Coordinator of Enrollment Services	Executive Director of Enrollment Services	Dean of Student Engagement
Repeat Course with a Grade of C or Higher				Dean of Student Engagement
Security	FSU Police 850-774-2705	Executive Director of Operations		College President
Student Activities	Student Government Association	Student Activities Coordinator		Dean of Student Life
Student Financial Accounts	Cashier	Bursar	Executive Director of Student Financial Services	Dean of Business Affairs
Students with Disabilities	Assistant Coordinator of Student Accessibility Resources	Coordinator of Student Accessibility Resources		Dean of Student Life
Student Grade Concerns	Faculty Member	Academic Division Chair		Vice President of Academic Affairs
Testing	Testing Assistant	Coordinator of Testing		Dean of Student Engagement
Transcripts	Transcript Evaluation Specialist	Coordinator of Enrollment Services	Executive Director of Enrollment Services	Dean of Student Engagement
Weekend Campus Contact	Campus Custodial Staff	FSU Police 850-774-2705		Vice President of Administration and Finance
Veteran Benefits	Coordinator of Veteran Services	Executive Director of Enrollment Services		Dean of Student Engagement
3rd Attempt of a Course	Counselor			Dean of Student Engagement
4th Attempt of a Course				Dean of Student Engagement



Panama City Campus
850.769.1551

Gulf/Franklin Campus
850.227.9670

North Bay Campus
850.747.3233

Tyndall Education Center
850.913.2910